

CleanSeal V3 (CL)
CleanSeal Exhaust V3 (CR)

Installation & Operating
Manual

1 Updates

Date	Revision	Object	Author
2021-04-29	D	Correct support bracket footprint values §8.4.1	V.Parkkoin
2020-09-18	C	Update to last MIP updates	V.Parkkoin
2020-09-14	B	Update MIP drive shaft connection §9.5.3	V.Parkkoin
2020-07-26	A	First issue	V.Parkkoin

2 Contents

1	Updates.....	2
2	Contents.....	3
3	Purpose & Scope.....	6
4	Quality Control.....	7
5	Goods Reception.....	7
6	Prior to Installation or Intervention.....	8
7	Product Presentation.....	9
7.1	Design Features	9
7.1.1	CleanSeal CL for Ceiling Installation	9
7.1.2	CleanSeal Exhaust CR for Wall Installation	9
7.2	Corrosion Resistance	10
7.3	Materials & Temperature Limitations	11
8	Installation of Housings	15
8.1	Unboxing & Handling.....	15
8.2	Recommended Cutout Dimensions.....	16
8.3	Suspension Mounting.....	17
8.3.1	Standard Suspension	17
8.3.2	Optional Suspension – Basic Plenum Hangers	18
8.3.3	Optional Suspension – KNAUF® Rapid Push-on Hangers	19
8.4	Compression Mounting	20
8.4.1	Standard Compression.....	20
8.4.2	Compression Mounting Options.....	21
8.4.3	Compression Mounting with Quick Clamping Kit.....	22
8.5	Duct Connection	23
8.5.1	D-Spigot	23
8.5.2	N-Spigot	24
8.5.3	Rectangular Flange	25
8.5.4	Open Plenum Versions	26
8.6	Measurement Port Connection.....	27

9	Installation of Add-ons	28
9.1	Dampers.....	28
9.2	Duct Adapters	29
9.3	Aerosol Injection.....	30
9.3.1	CleanSeal Integrity.....	30
9.3.2	IntegriBox.....	31
9.4	Mobile Integrity Probe (MIP).....	32
9.4.1	Special precautions when installing a MIP housing.....	33
9.4.2	Choosing the Control Box Location	34
9.4.3	Adapting and Operating the Control Box Locking System.....	35
9.4.4	Connecting the MIP Drive Shaft	37
9.4.5	Installing the Control Box	38
9.4.6	Installation Validation before Startup	39
10	Operation.....	40
10.1	Filter Compatibility	40
10.1.1	Gel Filter Compatibility.....	40
10.2	Filter Clamping - General Settings	41
10.3	CleanSeal CL for Ceiling Installation	43
10.3.1	Features	43
10.3.2	Front Plate Operation for CleanSeal CL.....	44
10.3.3	Filter Installation / Exchange	45
10.3.4	Local Aerosol Injection with IntegriPod.....	46
10.3.5	Controlling Multiple Housings with IntegriBox.....	47
10.3.6	Filter Validation for Supply Air.....	48
10.3.7	Filter Validation for Extract Air	48
10.4	CleanSeal Exhaust CR for Wall Installation	49
10.4.1	Features	49
10.4.2	Door Operation for CleanSeal Exhaust CR.....	50
10.4.3	Main Filter Installation / Exchange	51
10.4.4	Pre-filter Installation / Exchange	52
10.4.5	Testing Shroud (Option)	53
10.4.6	Filter Validation with Mobile Integrity Probe	56
10.4.7	MIP Driver.....	58

11	Maintenance.....	59
11.1	Spare Parts.....	61
11.2	Procedures.....	62
11.2.1	Replacing Measurement Port Tubes	62
11.2.2	Adjusting Door Fit on CleanSeal Exhaust.....	63

3 Purpose & Scope

This manual is made for personnel in charge of housing installation and filter change & validation.

Its purpose is to introduce the product and provide necessary information regarding

- ➔ Housing installation
- ➔ Filter installation & exchange
- ➔ Filter validation
- ➔ General adjustment and operating procedures for housings and add-ons

for CleanSeal CL terminal housings for ceiling installation (supply- or extract air) as well as CleanSeal Exhaust CR for wall installation (extract air only) and associated Add-Ons.

PLEASE NOTE:

The CleanSeal product family is open to customization. Illustrations in this manual represent generally valid principles for the standard scope. The actual configuration of your specific CleanSeal might be different, depending on type and custom features.

DISCLAIMER

We would like to take this opportunity to thank our customers and other parties for their interest in Camfil filters, housings and products and to remind them that each user bears the full responsibility for making its own determination as to the suitability of Camfil materials, information, products, recommendations and advice for its own particular purpose.

Each user must identify and perform tests and analysis sufficient to assure that its finished parts, methods and results will be safe and suitable for use under end-use conditions. Because actual use of products, methods and information by the user is beyond the control of Camfil, such use is within the exclusive responsibility of the user and Camfil cannot be held responsible for any loss incurred through incorrect or faulty use of products or information.

Further, no statement contained herein concerning a possible, safe or suggested use of any material, method, product or advice is intended or should be construed to grant any license under any patent or other intellectual property right of Camfil or any of its subsidiaries or affiliated companies or as a recommendation for the use of such information, material, product, method, service or design in the infringement of any patent, copy write, trademark or other intellectual property right.

4 Quality Control

Quality control items for CleanSeal terminal housings are documented by Camfil Qualified Sub Contractors on the corresponding checklist, according to a product specific Quality Check Instruction.

The combination of order reference, date and batch serial number on the identification sticker allows Camfil to track quality documentation of any individual housing.

5 Goods Reception



Packing example:
3 CleanSeal housings

Packaging for shipment is covered by a Camfil specification, to ensure transport protection and delivery in good condition.

- The main box contains the housing and a bag with accessories



- For housings with MIP (Mobile Integrity Probe), the control box will be included with the housing.
- As a general rule, other add-ons and accessories (front plates, doors, dampers, adapters, etc.) will be packed separately.

△ PLEASE NOTE:

- Each package or pallet should be checked upon delivery (visual check), to ensure there has been no damage during transport..
- In case of Quality issues not linked to transport, please provide a short description (ideally with picture) of the feature concerned, as well as a picture of the housing's identification sticker for tracking.

6 Prior to Installation or Intervention

 **Precautions :** Respect applicable safety and health rules on site and wear protective gear. (clothing, gloves, eye protection, safety footwear, mask, ...).

A work coat or overall and gloves are recommended as a minimum precaution.

As a general rule

- ➔ Store parts in a dry area protected from weather, prior to installation
- ➔ Airflow through installed housings should be shut off before intervention, unless specifically required for validation testing

7 Product Presentation

7.1 Design Features

CleanSeal housings are designed as terminal housings for air supply or extraction in clean rooms.

CleanSeal housings (CL) for ceiling installation are designed for supply air, but can perfectly work as extract air terminals in the ceiling.

CleanSeal Exhaust housings (CR) for wall installation are designed for extract air.

Global Features

- Fully welded design, including measurement ports
- Tool-less filter clamping
 - Filter retainers (ceiling) / door stops (wall) for hands-free operation of clamps
 - Long lasting reliability and air tightness due to fully welded construction
 - Proven high corrosion protection against decontamination agents
 - Safe and fast locking / unlocking of front plates and doors
 - Installation by suspension (only for ceiling installation) or compression using removable “universal blocks”
 - Large choice of standardized sizes, materials, and inlet options

7.1.1 CleanSeal CL for Ceiling Installation

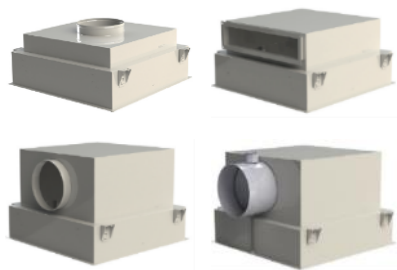

- Available for PU filters (frame heights 66 / 78 / 90 / 110 mm)
- Available for Gel filters (frame heights 71 / 105 / 115 mm)
- Optional PRE filter (frame height 48 / 50 mm) for exhaust (❖ *standard selection*)
- Full range of interchangeable front plates
- Available with Manual Integrity Probe (❖ *standard selection*)

7.1.2 CleanSeal Exhaust CR for Wall Installation



- Available for PU filters (frame heights 66 / 78 / 90 / 110 mm)
- Available for Gel filters (frame heights 71 / 105 / 115 mm) (❖ *custom option*)
- Optional prefilter (frame height 48 / 50 mm) (❖ *standard selection*)
- Available as open-plenum version
- Available with Manual Integrity Probe (❖ *standard selection*)

7.2 Corrosion Resistance

Standard housing versions feature a double-layer powder coat for enhanced corrosion protection, designed to be highly resistant to decontamination agents commonly used in Life Science and Clean Process environments.

Camfil has chosen to evaluate corrosion resistance of its metal products with respect to decontamination products most commonly used by our customers.

- Hydrogen Peroxide (H₂O₂)
https://en.wikipedia.org/wiki/Hydrogen_peroxide
- Peracetic Acid (CH₃CO₂OH)
https://en.wikipedia.org/wiki/Peracetic_acid
- Actril™ Cold Sterilant
<http://www.medivators.com/products-and-services/renal-systems/cold-sterilants>

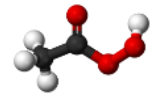
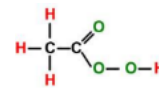
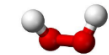
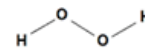

➔ A comprehensive testing report is available, upon request

➔ Corrosion resistance to other decontaminants can be determined in our laboratory, upon request

PLEASE NOTE:

CleanSeal is designed for indoor use in Life Science applications with HVAC processed air. No corrosion resistance class according to ISO 12944 is established. Store parts in a dry area protected from weather, prior to installation.

In environments with high condensation risk, we recommend using stainless steel versions.

7.3 Materials & Temperature Limitations

From the technical characteristics of component materials (paint & plastic parts) it is safe to say that CleanSeal housings are fully functional for the same temperature range as the corresponding Camfil Megalam filter panels, i.e. 60°C maximum for continuous use.

-  **PLEASE NOTE:** HOT process air and/or environment
Under no circumstances should a housing be continuously exposed to temperatures > 90°C.

-  **PLEASE NOTE:** COLD process air
In case of very cold process air, there is a risk of passing the dew point of the ambient atmosphere, which would lead to potentially heavy condensation, with consequences such as water damage, accelerated corrosion, etc.
For such applications, we recommend using stainless steel versions and / or an optional thermo-insulation layer.

The following materials are used in CleanSeal filter housings.

- ➔ Max. temperatures are values for permanent exposure.

Illustration	Name	Material(s)	Temp. Max [°C]
Common Parts CleanSeal Supply (CL) & CleanSeal Exhaust (CR)			
	Housing Body	(a) 1.0038 (S235JRG2) (b) SS 1.4301 (X5CrNi18-10) 1.4307 admissible (c) SS 1.4404 (X5CrNiMo17-12-2)	(>250)
-	Housing Coating	Epoxy primer Polyester top coat	(<=90)
	Support Bracket	1.4301 (X5CrNi18-10)	(>250)
	Support Bracket	1.4404 (X5CrNiMo17-12-2)	(>250)
	Clamping Bracket Plate	1.4301 (X5CrNi18-10)	(>250)
	PU GEL Excenter Clamp	Aluminum Al 6063-T6 PA6-GF30	(<=177) (<=100)
	Hinge Pin	POM	(<=70)
	Tube Cap for tube D8	PBT POM NBR	(<=70)
	Air Tubing, green D8d6	Polyurethane	(<=60)
	Stickers	PET	(<=70)
-	Screws & Nuts & Fittings	(a) Zn8C (b) SS A2 (c) SS A4	(>250)
-	Powder Coat Primer Topcoat	Epoxy Polyester	(<=90)



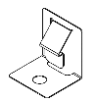

Illustration	Name	Material(s)	Temp. Max [°C]
Specific Parts CleanSeal Supply (CL)			
	Retainer Bracket	1.4301 (X5CrNi18-10)	(>250)
	Retainer	1.4310 (X10CrNi18-8)	(>250)
	Spring Base	1.4404 (X5CrNiMo17-12-2)	(>250)
	Spring	1.4310 (X10CrNi18-8)	(>250)
	Damper Adj. Bar	1.4301 (X5CrNi18-10)	(>250)

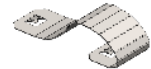

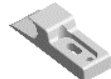
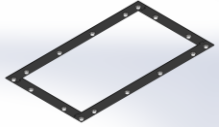

Illustration	Name	Material(s)	Temp. Max [°C]
Specific Parts CleanSeal Exhaust (CR)			
	Spring Holding Plate	1.4301 (X5CrNi18-10)	(>250)
	Prefilter Holding Spring	1.4310 (X10CrNi18-8)	(>250)
	Wire Harness D6,4	PA6.6 - UL94 V-2	(≤100)
	Mini-Latch SS (Spring Box)	Stainless Steel Plastic	(≤70)
	Mini-Latch Hook	Plastic	(≤70)

Illustration	Name	Material(s)	Temp. Max [°C]
Other Parts			
	Flange Gaskets	1.4301 (X5CrNi18-10)	(<=90)
	MIP Sampling Tube	Silicone	(<=135)
	MIP Drive Flexible Shaft	Stainless Steel PVC	(<=80)

8 Installation of Housings

8.1 Unboxing & Handling

- Open the TOP of the box (see pictogram on the side of the box)
- Retrieve the bag(s) of accessories and remove protective foam parts
- Damper ready S-C-versions will contain a second pouch with the damper adapter rod.



- Extract housing from the box using the duct hole as a grip. DO NOT lift the housing by the dp-port tube.
- We recommend keeping spigot and flange protection in place to prevent handling damage. Detach and dispose of at the last possible opportunity:



- Install the housing directly or place flat on a **protected** surface to avoid scratching

△ Check filter height clamp settings at this point and adjust, if necessary ([see also § 10.2](#)).

△ **PLEASE NOTE:** The ceiling / wall flange is the most fragile part of the housing. Accidental bending will result in paint cracks which, in turn, will compromise corrosion protection.

Avoid shocks and supporting the housing weight by the flange or flange corners:

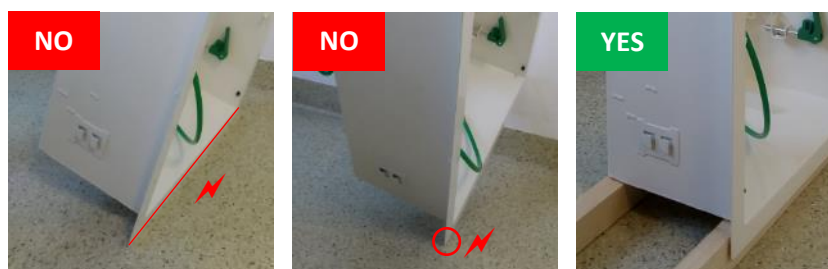

8.2 Recommended Cutout Dimensions

- Recommended cutouts ensure a recovery area of 5 ... 10 mm with the standard 20mm flange
- Dimensions are generally +7mm of the respective max. housing dimension, with reduced cutout height B +4mm for wall-mounted CR housings .
For housings without standard supports (custom), some cutout dimensions can be reduced for additional recovery, i.e. more latitude for cutout precision

Standard cutouts

for **CEILING** installation – CleanSeal CL

for **WALL** installation – CleanSeal Exhaust CR

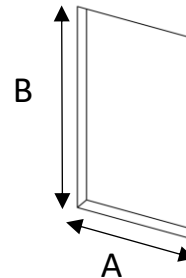
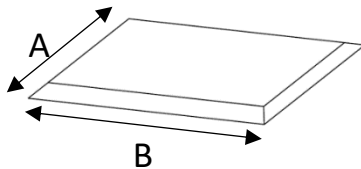

CL	Filter Size	A [mm]	B [mm]
Square	3P3	374	374
	4P4	526	526
	5P5	577	577
	6P6	679	679
	9P9	987	984
Rect.	3P6	374	667
	9P6	679	972
	11P5	577	1165
	12P6	679	1277

CR	Filter Size	A [mm]	B [mm]
Square	3P3	374	359
	6P6	679	664
Rect.	3P6	374	664
	9P6	679	969

Control Box	A [mm]	B [mm]
	360	167

Integri Box	A [mm]	B [mm]
Size 1	182	167
Size 5 & 10	374	359

PLEASE NOTE: For best results, cutout precision should be at tolerances +0 / -2mm.
See your project drawing for integration dimensions of customized products.

8.3 Suspension Mounting

8.3.1 Standard Suspension

The standard CleanSeal support system allows housing installation by both suspension and compression for most practical situations.

- Recommended cutouts (see § 8.2) will allow to insert any standard housing straight, no balancing required
- General purpose stainless steel support brackets are included as accessories with every housing
- Suitable for threaded rods M8 or other suspenders $D_{max} = 9mm$

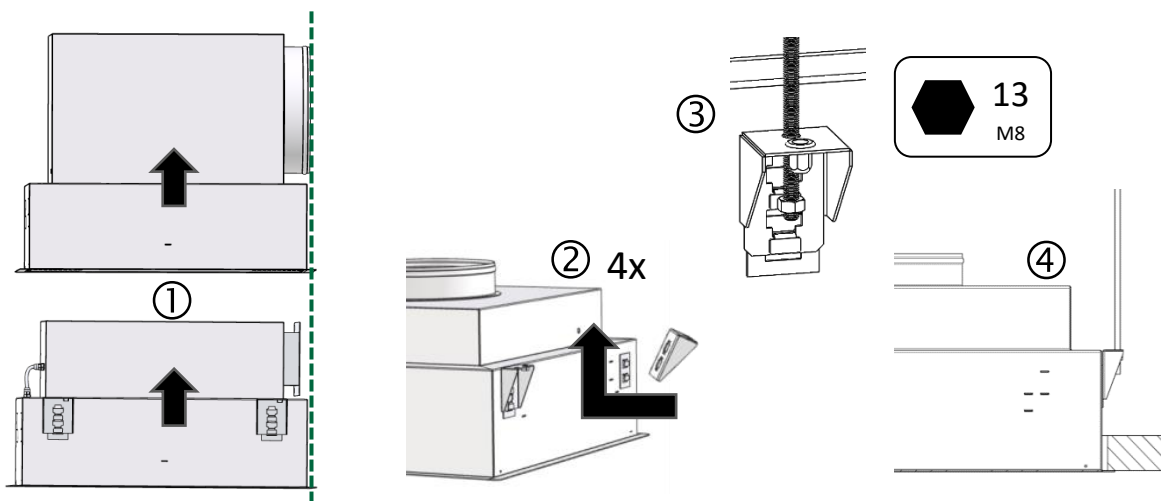

Footprint for suspender positioning

for **SQUARE** housings

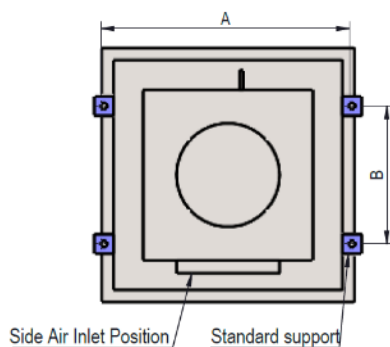

Size	A [mm]	B [mm]
3P3	391	215
4P4	543	367
5P5	594	418
6P6	696	520
9P9	1001	825

for **RECTANGULAR** housings

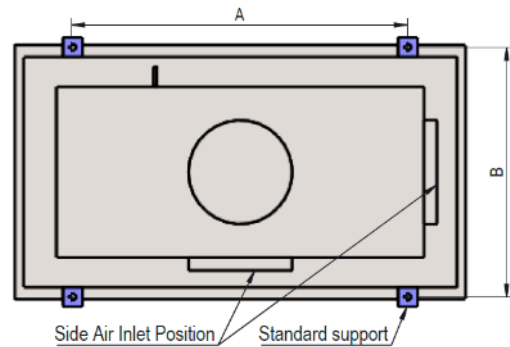

Size	A [mm]	B [mm]
3P6	520	391
9P6	825	696
11P5	1018	594
12P6	1130	696

8.3.2 Optional Suspension – Basic Plenum Hangers

CleanSeal ceiling housings (CL) can be optionally supplied with alternative supports, where the standard support system is not suitable

PLEASE NOTE: Suspension options require customized housings with the corresponding option. They are NOT retrofittable.

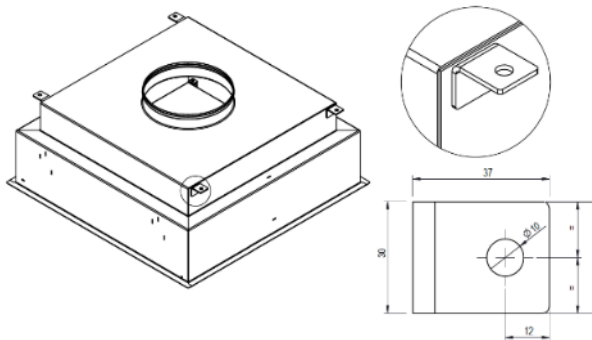

- Suspension from plenum for minimum ceiling cutout dimensions
- Standard support brackets are replaced by support angles welded to the plenum
- Suspension with 4x M8 threaded hangers or other suspenders $D_{max} = 9\text{mm}$ ($\varnothing 10\text{mm}$ holes)

Footprint for suspender positioning

for **SQUARE** housings

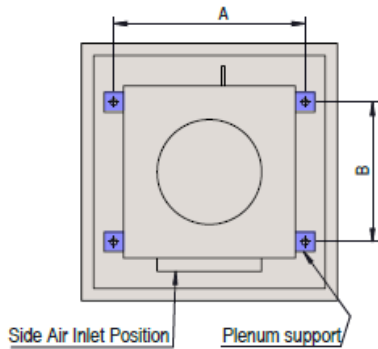

Size	A [mm]	B [mm]
3P3	303	213
4P4	455	365
5P5	506	416
6P6	608	518
9P9	913	823

for **RECTANGULAR** housings

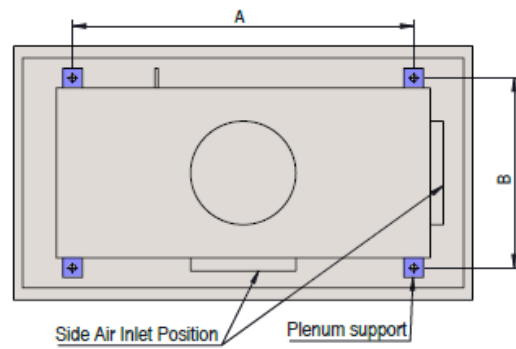

Size	A [mm]	B [mm]
3P6	518	303
9P6	823	608
11P5	1016	506
12P6	1128	608

8.3.3 Optional Suspension – KNAUF® Rapid Push-on Hangers

CleanSeal ceiling housings (CL) can be optionally supplied with alternative supports, where the standard support system is not suitable

PLEASE NOTE: Suspension options require customized housings with the corresponding option. They are NOT retrofittable.

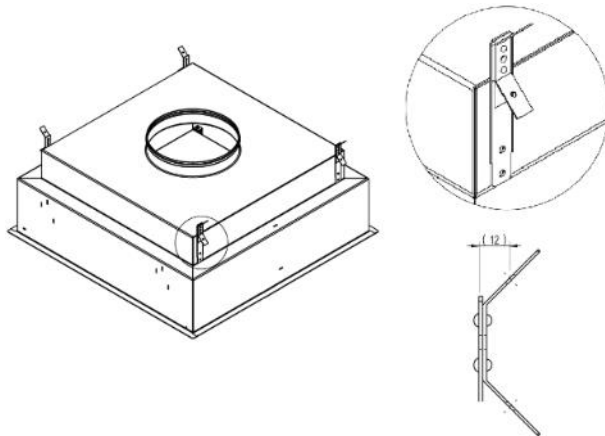

- Push-on solution for fast installation
- Suspension from plenum for minimum ceiling cutout dimensions
- Standard support brackets are replaced by KNAUF® Rapid Hangers
- 4x straight rods \varnothing 4mm - no thread

Footprint for suspender positioning

for **SQUARE** housings

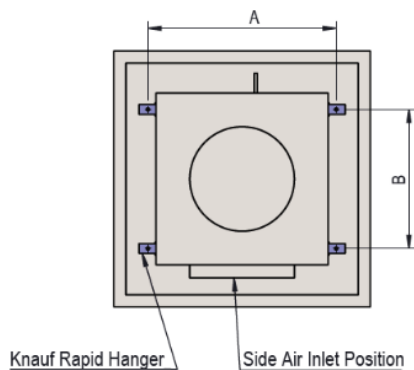

for **RECTANGULAR** housings

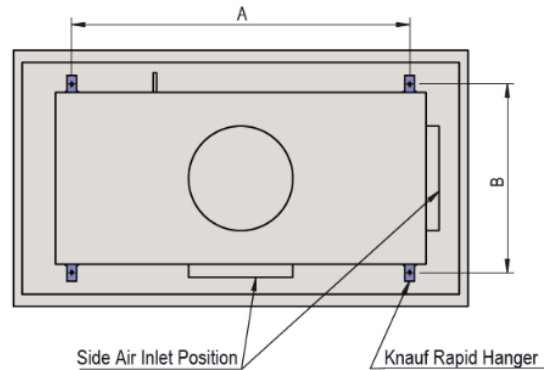

Size	A [mm]	B [mm]
3P3	287	213
4P4	439	365
5P5	490	416
6P6	592	518
9P9	897	823

Size	A [mm]	B [mm]
3P6	518	287
9P6	823	592
11P5	1016	490
12P6	1128	592

8.4 Compression Mounting

8.4.1 Standard Compression

The standard CleanSeal support system allows housing installation by both compression and suspension for most practical situations.

- Recommended cutouts (see § 8.2) will allow to insert any standard housing straight into the cutout, no balancing required
- General purpose stainless steel support brackets are included as accessories with every housing

PLEASE NOTE: Compression mounting requires “Option B” - Pressure Screw Kit for 1 housing (4x) to be ordered separately: **Ref. 1068200**

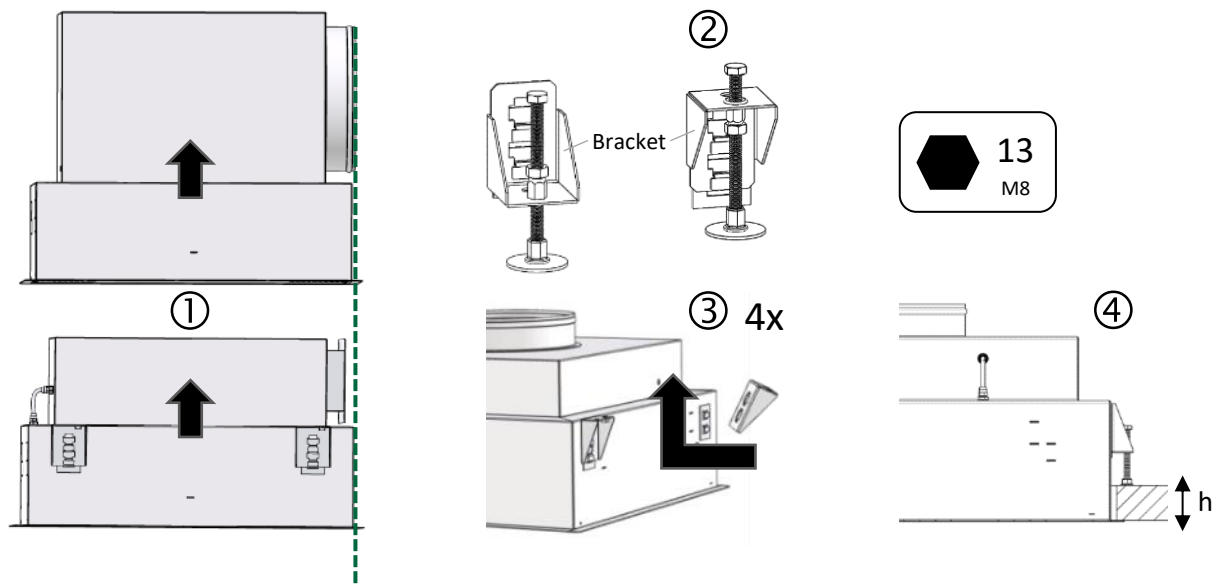

Bracket positioning

Orientation ①



for panel thickness

min ca. 30 mm

max < 65 mm

Orientation ②



min > 65 mm

max ca. 105 mm (... 120 mm *)

A* / B* +

PLEASE NOTE:
For the maximum necessary integration space in compression mounting, including enlarged pressure plates of Option B, please add
+88 mm (2x19 + 2x25mm)
To the “footprint” values from § 8.3.1

↑ if pressure screw is assembled on the inserted housing with brackets in place !

8.4.2 Compression Mounting Options

Compression installation on ceiling or wall panels thicker than 120 mm will require modified brackets.

PLEASE NOTE: An optional kit is available for panel thicknesses up to 165 mm to be ordered separately:

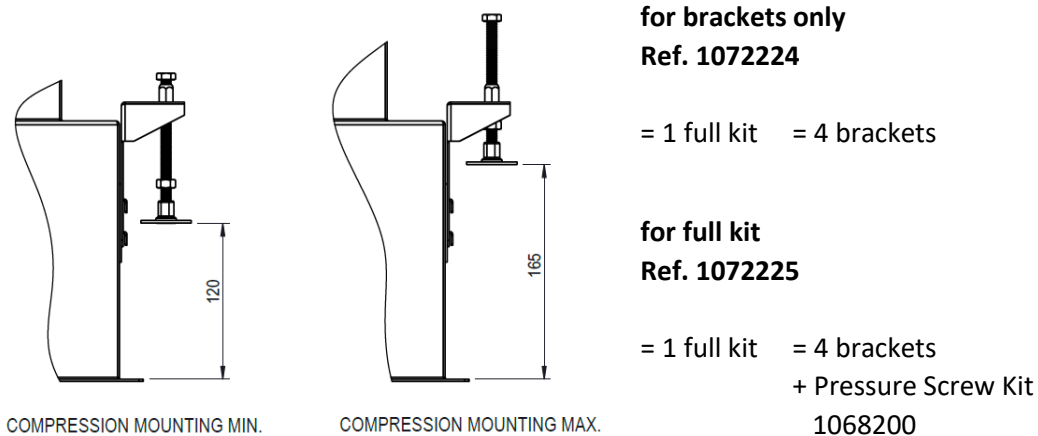

PLEASE NOTE: For compression mounting on even thicker panels, custom brackets can be proposed, subject to project-specific feasibility study and quotation.

➔ **Please contact your Camfil representative.**

8.4.3 Compression Mounting with Quick Clamping Kit

The patented Quick-Clamping-Kit is designed for fast & reliable mounting in areas with difficult access.



- Installation in 5 minutes or less with access from one side only
- Suitable for both wall and ceiling installation
- For all housings with standard filter chassis & clamping bracket interface

Size	Weight	Wall thickness	Item No.	Size	Weight	Wall thickness	Item No.
3P3	2,9 kg	18-38 mm	1076207	6P6	4,6 kg	18-38 mm	1076213
		34-54 mm	1077069			34-54 mm	1077071
		50-70 mm	1076209			50-70 mm	1076215

Size	Weight	Wall thickness	Item No.	Size	Weight	Wall thickness	Item No.
3P6	4,2 kg	18-38 mm	1076210	9P6	5,9 kg	18-38 mm	1076216
		34-54 mm	1077070			34-54 mm	1077072
		50-70 mm	1076212			50-70 mm	1076218

PLEASE NOTE: For compression mounting on thicker panels custom locking plates can be proposed:

With standard housing	<= 95 mm max
With custom housing	subject to project-specific feasibility study and quotation.

➔ Please contact your Camfil representative.

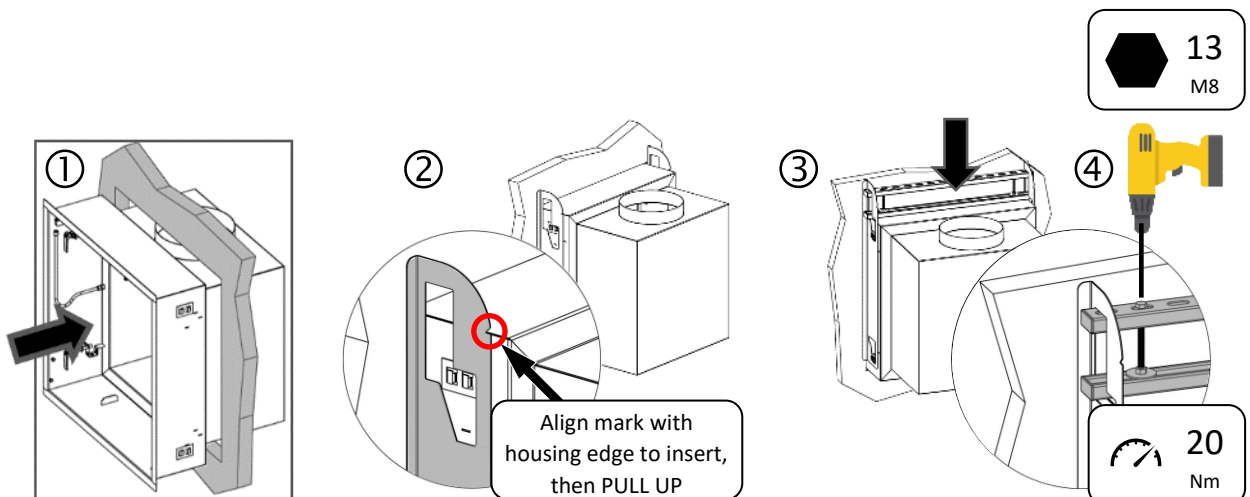

PLEASE NOTE: A detailed instructional video is available for preparation and installation using the Quick Clamping Kit

➔ Please contact your Camfil representative.

8.5 Duct Connection

CleanSeal housings are supplied with different air hookup connections, depending on type and custom features.

8.5.1 D-Spigot

This female spigot form is used as standard on CL ceiling and CR wall housings. It is compatible with plug & play catalogue ducting elements with double-lip gasket (e.g. LINDAB® Safe Click, or equivalent), to ensure EUROVENT Class-D-airtightness.

A male spigot interface for flexible duct hookups may be emulated with a catalogue M-M adapter.

Ø Nom. Duct	B [mm]
160	162
200	202
250	252
315	317
355	357
400	402
500	502
560	562

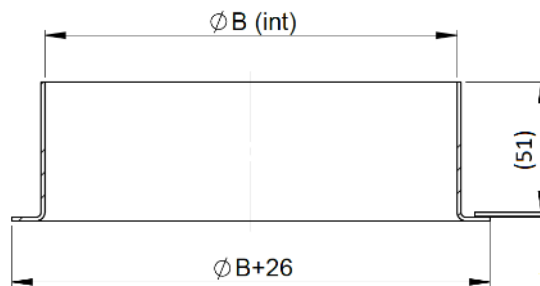

Optional M-M Adapter (not included)

Hookup

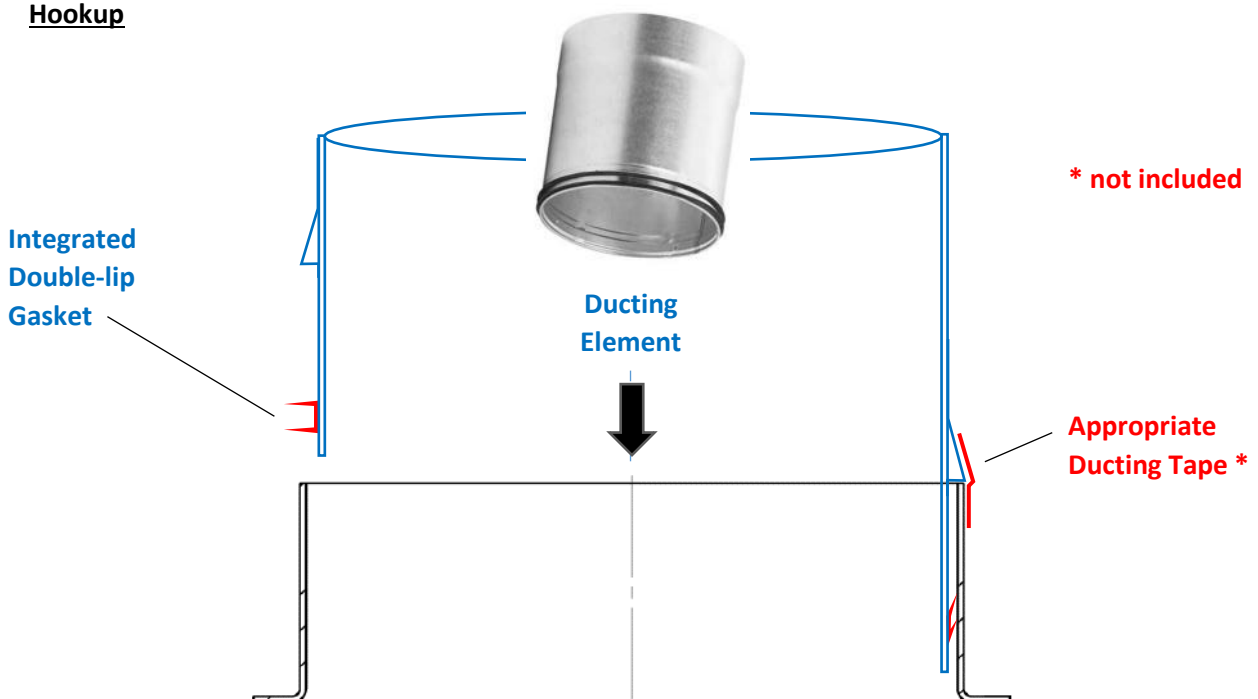

8.5.2 N-Spigot

This male spigot form may be ordered as a custom feature on any housing, where an adapter solution is not convenient ([see § 8.5.1](#)), except CL ceiling housing type “damper ready”.

It is designed for airtight general purpose hookup to most ducting systems, both rigid and flexible.

Ø Nom. Duct	A [mm]
160	156
200	196
250	246
315	311
355	351
400	396
500	496
560	556

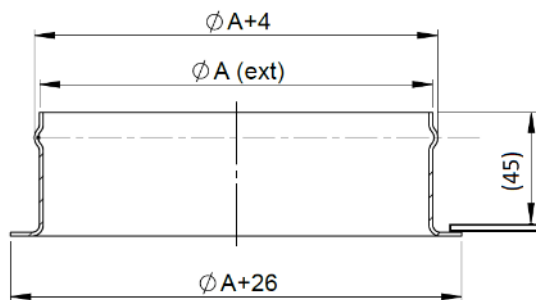

Hookup

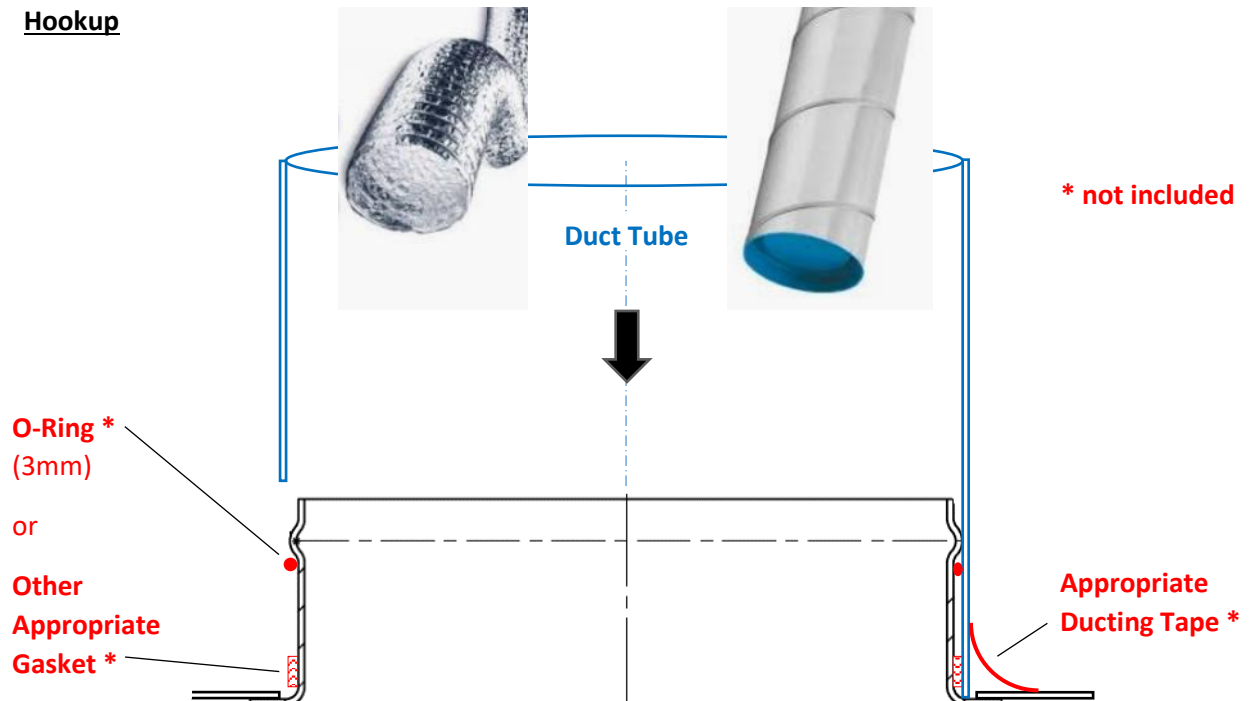

8.5.3 Rectangular Flange

This flange form is available on many standard housings.
 May also be used as a custom feature on any housing.
 It is specifically suitable where integration space is at a premium.

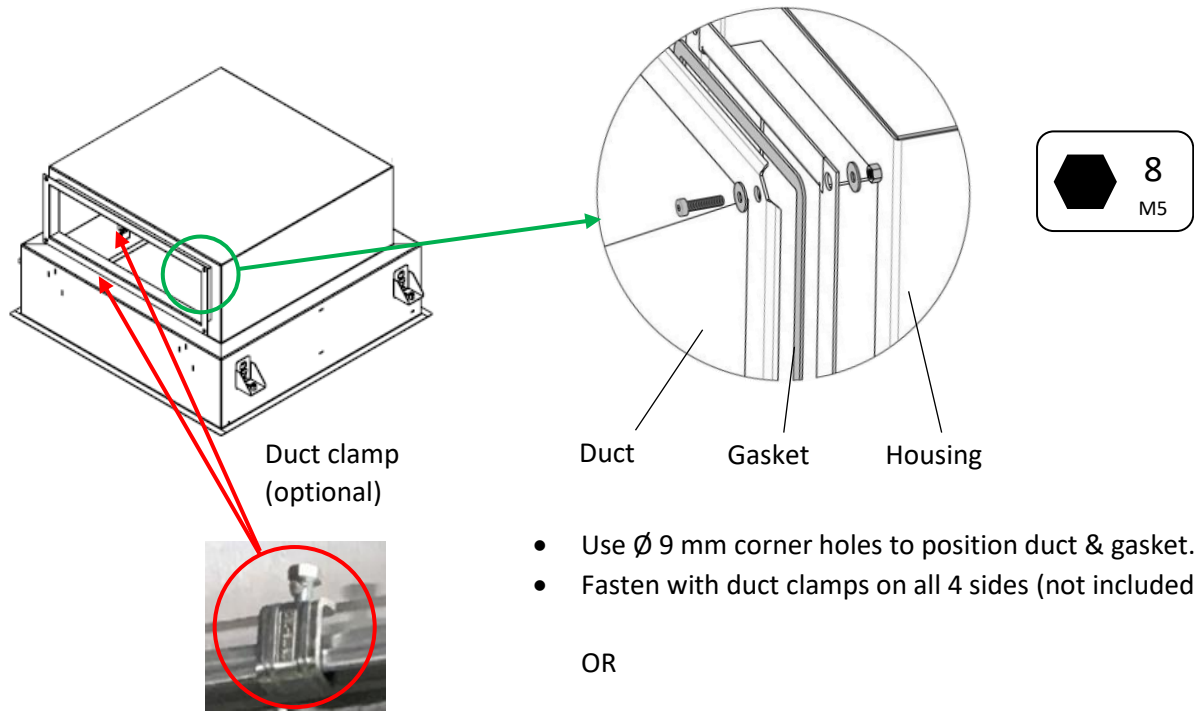

- Use $\varnothing 9$ mm corner holes to position duct & gasket.
- Fasten with duct clamps on all 4 sides (not included).

OR

- Fasten on corners using M5 bolts.

PLEASE NOTE: For most sizes, corner screws should be sufficient to achieve airtight connection. Depending on gasket hardness and the stiffness of the duct flange, additional duct clamps may be necessary on the long side.

PLEASE NOTE: Gasket material should be chosen at customer's discretion, depending on operating temperature and potential chemical aggression.

For general purpose in Life Science, we recommend :

- Form gasket - closed-cell EPDM foam, type EPDM - ASTM D 1056 - 2 A2 - 4 mm.

OR

- Strip gasket (adhesive), PE, type Lindab RJSM (or equivalent) - 4 mm.

Caution: When using strip gasket material, take care to make clean, straight cuts and apply without gap to avoid flange leaks.

8.5.4 Open Plenum Versions

This housing variant without a plenum is used for direct attachment of the duct to the filter chassis. It is available as a standard version for both CL ceiling and CR wall housings. May also be used as a custom feature with specific dimensions on any housing.

PLEASE NOTE: For custom versions, the hole size and pattern of the flange may vary. Consult your project drawing.

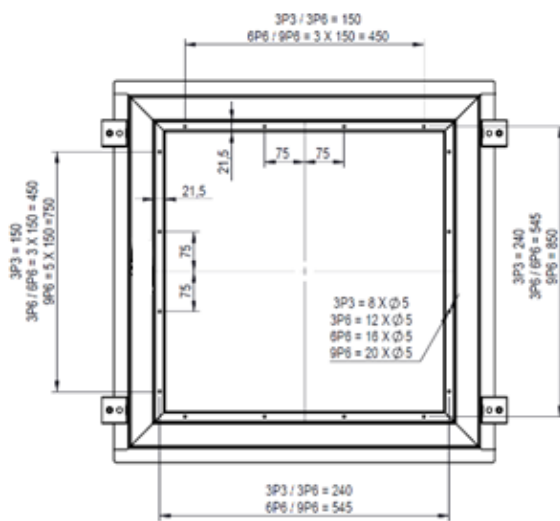

- Position gasket & duct
- Fasten with bolts

Flange connections are accessible through the front of the housing.

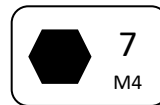

PLEASE NOTE: Gaskets can be proposed

Gasket Size	Ref.
3P3	1075821
3P6	1075822
5P5	in preparation
6P6	1076009
9P6	1076010

Gasket Material:
EPDM - ASTM D 1056 - 2 A2 - 4 mm

Custom dimensions subject to project-specific feasibility study and quotation.

➔ Please contact your Camfil representative

8.6 Measurement Port Connection

Every housing is fitted with a complete suite of fully welded measurement ports

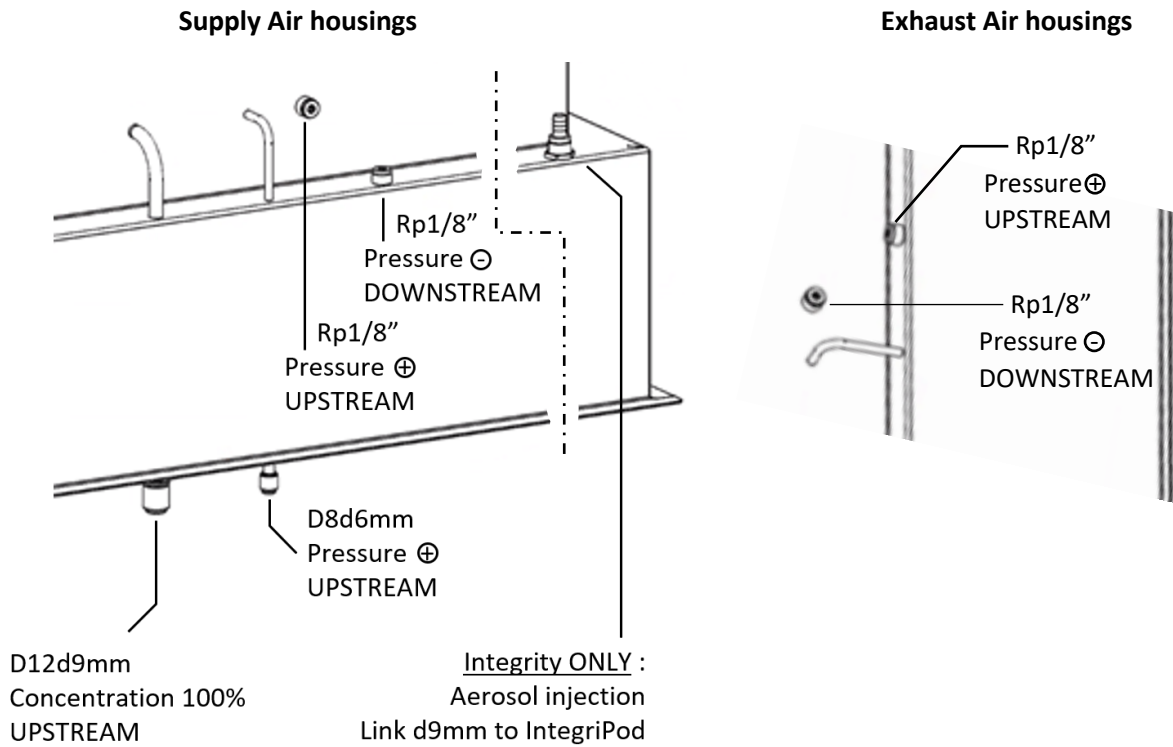

To activate the secondary dp-ports, e.g. for remote sensor hookup, proceed as follows:

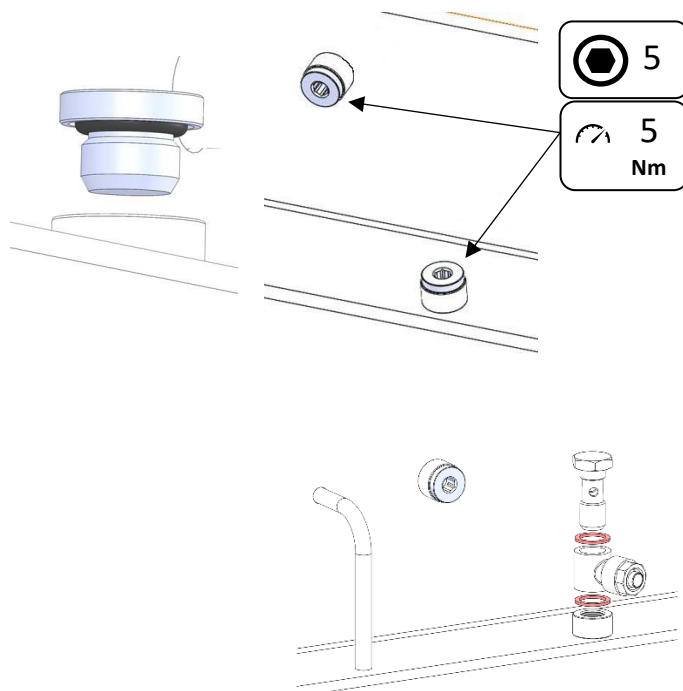

9 Installation of Add-ons

9.1 Dampers

PLEASE NOTE: The installation of either shut-off or regulation dampers as standard add-ons requires a “damper ready” S-C-housing or a customized T-C-housing.

Interface parts like the adapter rod and locking screws are included as accessories with the housing.

Dampers are packed separately from the housing.

→ For shut-off dampers discard fixing screws
→ For regulation dampers replace with screws + springs + washers from damper accessory kit and adjust to desired friction strength

→ Adjust dampers from the technical area above by turning the damper handle

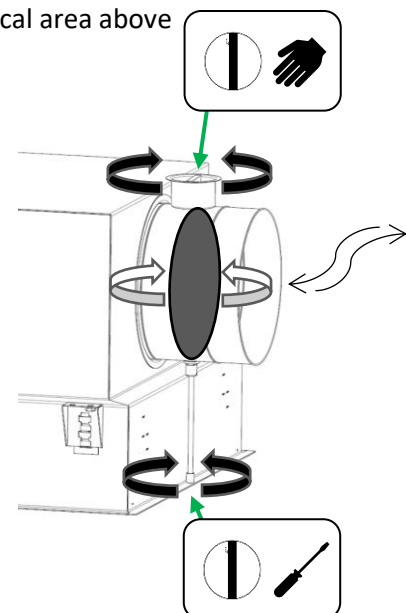

or

→ from the room below by turning the adapter rod

9.2 Duct Adapters

Rectangular-to-circular adapters allow for use of S-R-housings with circular ducting where integration space is at a premium.

Standard sizes are available for standard S-R flange sizes in 2 material options :

Rect. x-y [mm]	Round [mm]	Ref.	
		GALVANIZED	SS 304
200x100	160	1077082	1077091
200x100	200	1077083	1077092
200x200	250	1077084	1077093
350x100	200	1077085	1077094
350x150	250	1077086	1077095
400x150	315	1077087	1077096
400x200	315	1077088	1077097
500x150	315	1072256	1077098
500x200	355	1072258	1077099
600x200	355	1077089	1077100
800x150	355	1077090	1077101

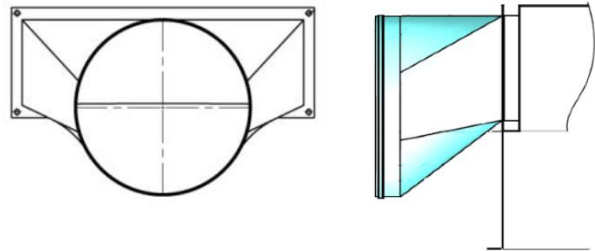

Other dimensions are possible as custom versions.

➔ Please contact your Camfil representative

Adapters to be fixed with 4 bolts and 12 mm self-adhesive gasket.

- Apply on the flat part of the flange, next to the bending radius.

⚠ Caution: When using strip gasket material, take care to make clean, straight cuts and apply without gap to avoid flange leaks.

- Cut out part of the angle or punch a hole to make way for the corner bolts.

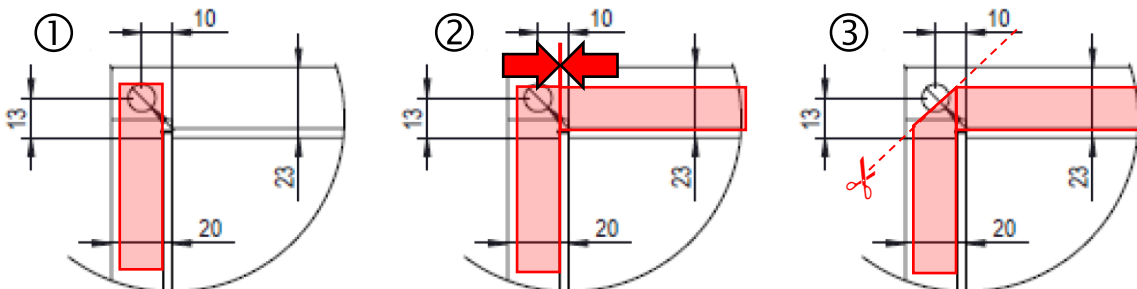

- For connection to the housing, [see § 8.5.3](#).

9.3 Aerosol Injection

For HEPA filter validation purposes, CleanSeal supply air housings can be fitted with the necessary features for aerosol injection.

Every CleanSeal CL ceiling housing is equipped with a full suite of measurement ports for filter control and validation. This can be completed with a qualified IntegriPod injection pod to provide optimum conditions for filter validation according to ISO 14644-3, using the remote IntegriBox terminal ([see § 9.3.2](#)).

The CleanSeal Integrity version is supplied as a complete kit including an additional local injection port and ducting pod with injection probe.

Should a retrofit of non-Integrity housings be required, customized solutions can be proposed.

➔ **Please contact your Camfil representative**

9.3.1 CleanSeal Integrity

CleanSeal Integrity supply air housings include additional features :

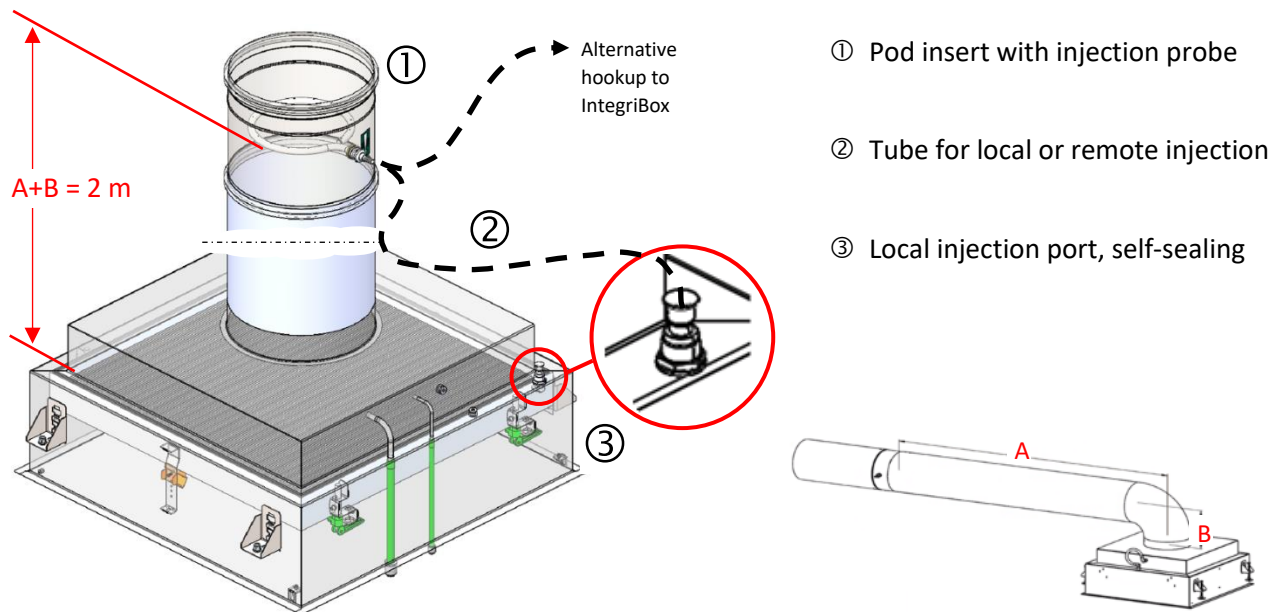

- Install housing as convenient, [see also § 8](#).
- For best results **install the pod insert 2m upstream** (distances A+B) from the filter, with either rigid or flexible ductworks.
This configuration will allow for optimum particle distribution upstream of the filter, using minimum aerosol quantities, distribution performance exceeding the prescriptions of ISO 14644-3 / IEST-RP-CC034.4. Testing reports available on request.
- In case of short upstream ducts, installation distance may be reduced while still being ISO compliant.
➔ **Please contract Technical Support via your Camfil representative for details**

9.3.2 IntegriBox

IntegriBox is an optional interface for remote aerosol injection and upstream pressure readings. Up to 5 (up to 10 depending on injection line length) housings can be controlled from one box.

The Cleanroom Box features a fully welded box with identical flange and clamping system as the filter housings, designed for integration into a wall or ceiling panel. For cutout dimensions, [see § 8.2](#).

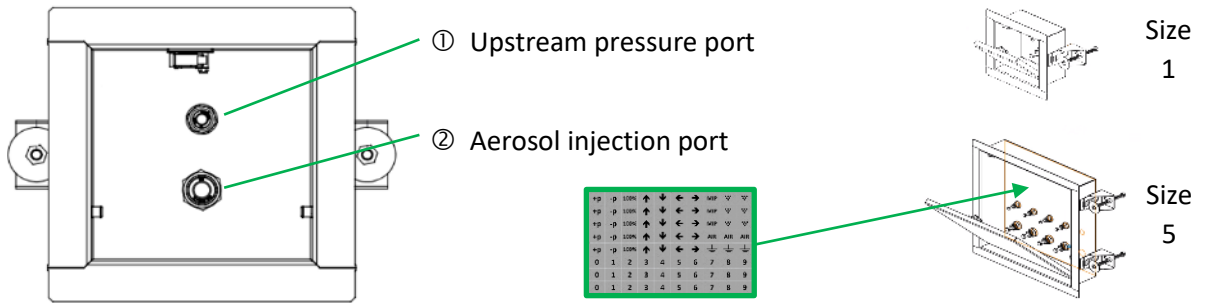

Stickers from the labelling chart (packaged in the accessory bag) may be used to label port attribution in the IntegriBox.

- ➔ The Technical Box features the same port interfaces, plus one additional port for the deported room pressure, integrated in a standard cabinet, to be mounted on the wall in the technical area.

- ⚠ **PLEASE NOTE:** Some particle loss will occur, depending on the injection tube length. Choose the IntegriBox location carefully to minimize particle loss. We recommend a max. of 5 housings per box with max. tube length of 20m, where possible.

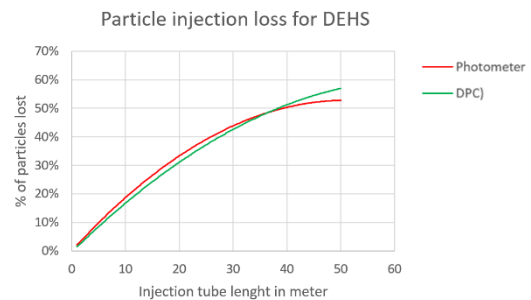
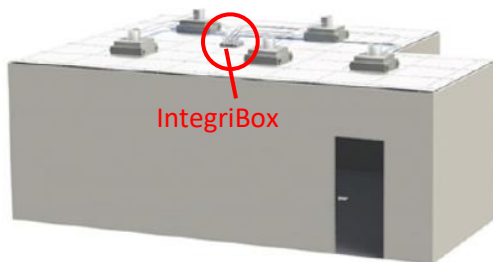

- When using IntegriBox, the local injection port on the housing (if present) should remain sealed.
- Avoid fittings, wherever possible, prefer consecutive tube lines.
- Avoid fittings with restricted section and narrow bends which might partially collapse the tubes.

- ⓘ **PLEASE NOTE:** Due to concentration loss in the tube lines, a 100% reading at the IntegriBox would present false readings. Both upstream 100% concentration and downstream sampling measurements have to be done directly at the housing port.

9.4 Mobile Integrity Probe (MIP)

The Mobile Integrity Probe (MIP) is a manual scanning system for exhaust air applications, integrated downstream into the housing and suitable for wall and ceiling installations.

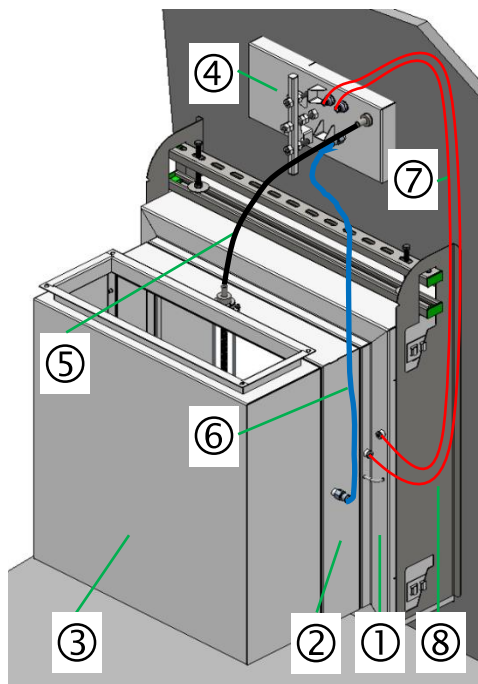

- ① Base housing – Open Plenum version
- ② MIP section (modular)
- ③ Plenum section (modular)
- ④ Control Box for MIP-drive and sampling port
- ⑤ MIP flexible drive shaft
- ⑥ Sampling tube
- ⑦ Manometer up- & downstream pressure tubes
- ⑧ Quick Clamping Kit (option)

△ PLEASE NOTE: Read the full instruction prior to installation.

Follow steps below, further detail is given in indicated sub-chapters.

Installation Steps

- Install the housing using special precaution, [see § 8](#) and [§ 9.4.1](#).
- Carefully choose the location of the Control Box before cutting the panel, [see § 9.4.2](#).
- Adapt the Control Box locking system to the panel thickness, [see § 9.4.3](#).
- Cut out the panel for housing and Control Box, [see § 8.2](#).
Cutout sizes, installation and related options for the respective housing are unaffected by the MIP device, but integration depth is increased.
Consult Scope Drawings or your Project Drawing for exact dimensions.
- Attach the MIP drive shaft ⑤ and the Sampling tube ⑥ to the housing drive port, [see § 9.4.4](#).
- Install port fittings and attach pressure tubes to the housing ports [see § 8.6](#).
- Install the housing (composed of ①②③) in the wall and attach the air duct, [see § 8.4](#).
- Attach the MIP drive shaft ⑤, the Sampling tube to the Control Box and the housing [see § 9.4.4](#) and connect pressure tubes to the manometer.
- **We recommend checking smooth MIP operation over the full displacement before installing and sealing the Control Box, [see § 9.4.6](#)**
- Install Control Box, [see § 9.4.5](#).
- Seal installation as required at customer's / contractor's discretion.

9.4.1 Special precautions when installing a MIP housing

△ IMPORTANT: Danger of damages from inappropriate unpacking or handling.

The housing is delivered fully assembled and tested.



Do not touch the scanning system during manipulation or installation as any deformation or misalignment might result in functional damage.

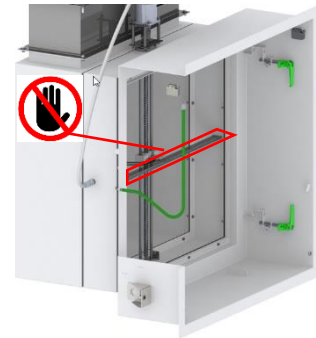

Protect the inside of the housing and especially the MIP support from dirt, etc. during installation or intervention.

In case of intervention through the housing, dismantle the probe and store in a safe location :

- Retain probe orientation for re-installation.
- Unplug the silicone sampling tube from the probe
- Loosen 2 screws ① to detach the probe, be careful not to lose washers and nuts ② that may fall out of the support slots.

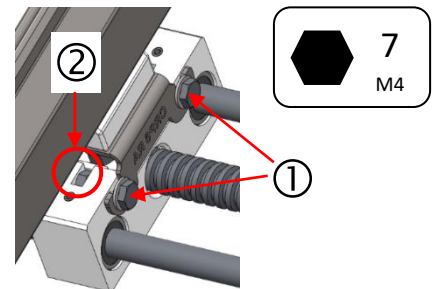

For re-installation, proceed as follows :

- Insert nuts into slots ②, install probe on the chariot - align and tighten 2 screws with washers.
 - The tube connector must be on the side of the housing sampling port fitting.
 - The probe opening must be parallel to the module frame and at a right angle to its support rails.
- Connect the silicone tube to its fittings.
 - The tube should always stay on the (back) side of the scan support and must never exceed the level of the probe opening (risk of filter damage in application).
Rotate tube prior to connecting, so that the natural tension keeps it on the correct side.
 - The plenum may contain a tube support bar. If so, the tube must pass behind the support.

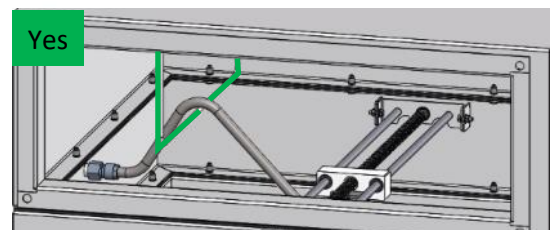
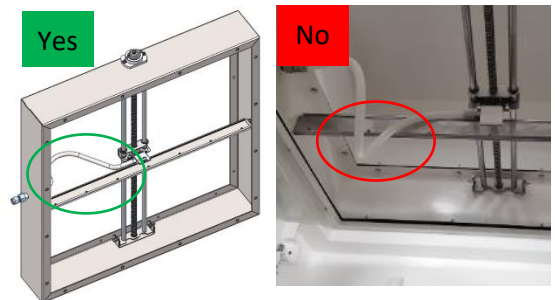

Please Note :

For 3P3 housings the distance is too small to avoid a collapse of the tube with conventional hookup. The tube needs to be installed in a loop.

9.4.2 Choosing the Control Box Location

The Control Box contains a manometer for filter pressure drop and the interface for the scan operation, i.e. the downstream sampling port and the mechanical drive port for the probe.

- PLEASE NOTE:** Keep in mind when choosing the Control Box location :
 It is also designed to serve as an access hatch to the technical area in case of intervention on tubing or the flexible drive shaft.
It should therefore be placed ideally on the side of the mechanical drive port.

Location areas with 700 mm standard drive shaft:

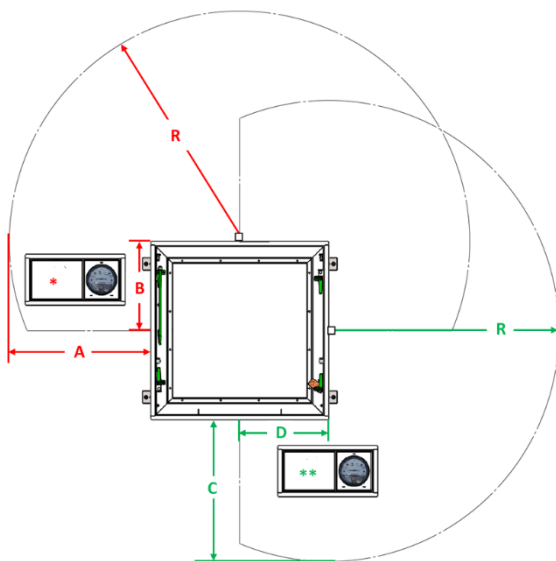

- **Std. drive port location** for the modular MIP module **is on TOP - ***
- For square housings, the **scan module** can be rotated by 90° increments.
- For rectangular housings, the **scan module** can be rotated by 180° increments.
Module separation and airtight reassembly required - DO NOT rotate the entire housing!
- **Drive port location for integrated MIP (probe in the plenum) is on the RIGHT - **.**
- These custom versions cannot be rotated.
- The location area will follow for the corresponding 90° orientation.

Housing Size	Location Area [mm]				
	R	A	B	C	D
3P3	800	590	360	590	360
3P6	800	590	360	440	335
6P6	800	440	335	440	335
9P6	800	440	335	X	X

Dimensions refer to the outer flanges.

➔ Please contact your Camfil representative

9.4.3 Adapting and Operating the Control Box Locking System

The Control Box locking system allows for quick operation with a single screw inside the box.

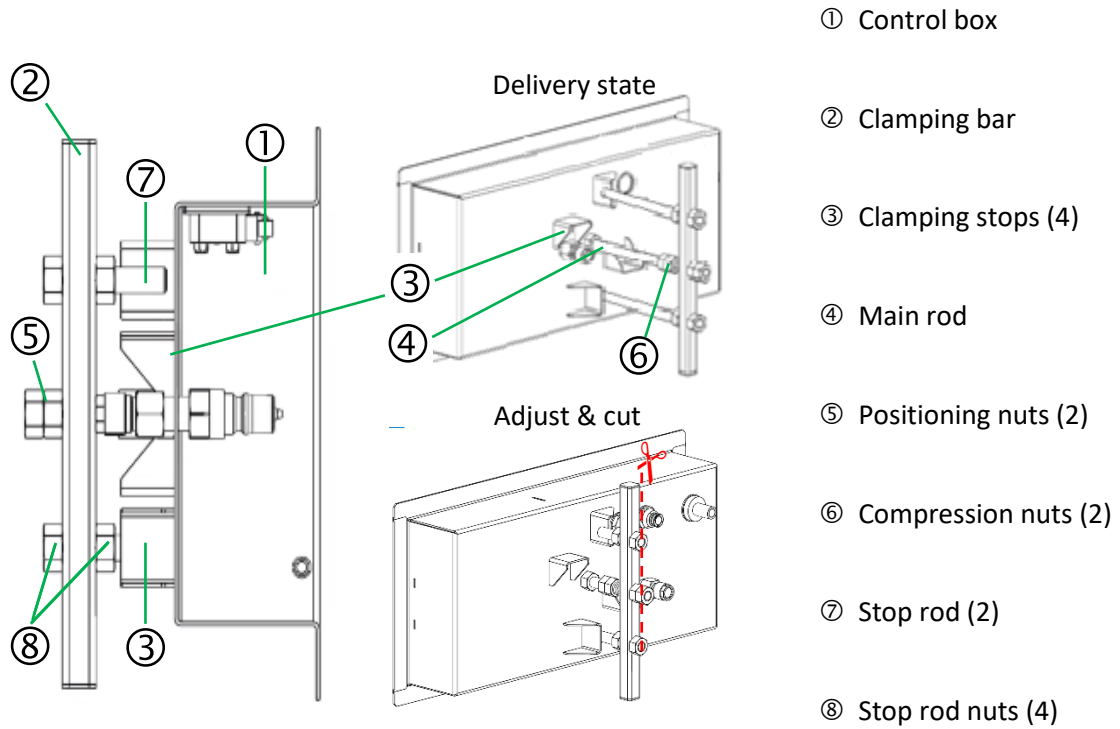

→ Locking system capability for **panel thickness**

min	40 mm
max	220 mm

→ For panels < 100 mm, use spacer blocks in the back of the panel :

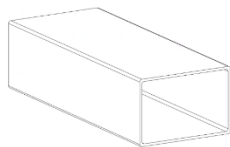

In case of border values,
use the smaller spacer !
e.g.
50 mm → 50 mm spacer

Spacer [mm]	Panel Thickness [mm]
none	100 - 200
10	90 - 100
20	80 - 90
30	70 - 80
40	60 - 70
50	50 - 60
60	40 - 50

Choose spacer material and fixing technology according to the panel.
The spacer will receive only compression forces, it may be fixed to the wall by double-sided tape.

Other panel thicknesses or customized locking solutions may be possible, subject to project-specific feasibility study and quotation.

→ **Please contact your Camfil representative**

Prior to installation, the clamping system has to be adapted to the panel thickness P :

→ Calculate the main rod length as : **X = Panel P [+Spacer] – 50 [mm]**

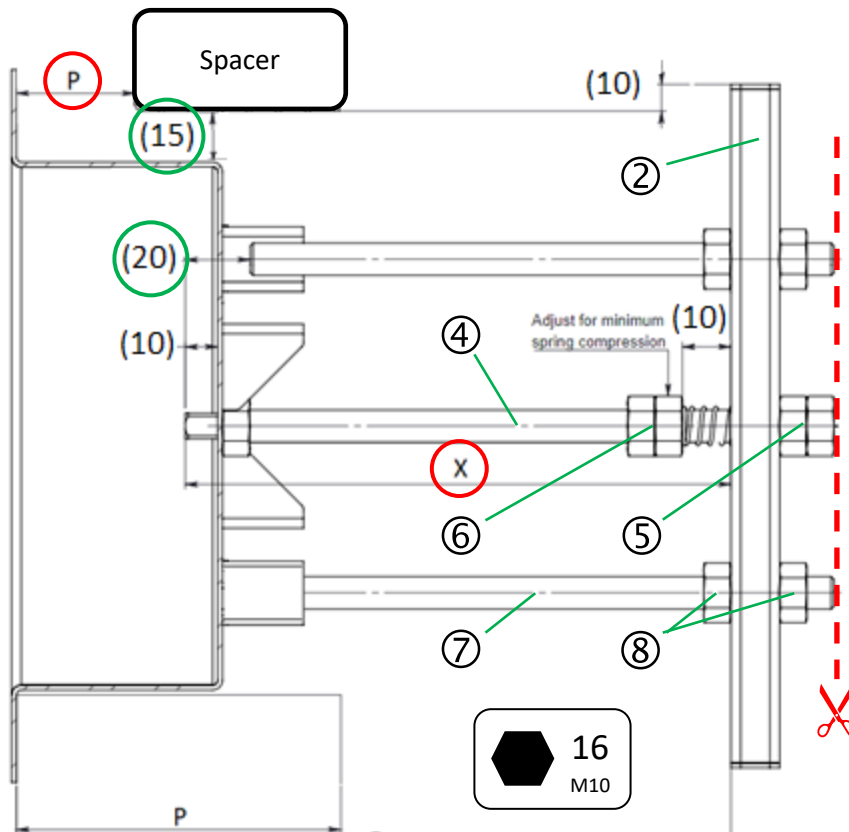

Place the clamping bar ② with stop bars ⑦ between the flats of the stops:

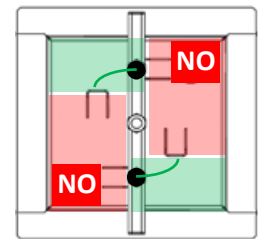

Position spacers at a slight vertical offset from the cutout
Align spacer center approx. with center of the cutout

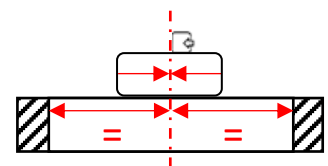

Adaptation Steps

PLEASE NOTE: Read the full instruction prior to installation.

- Determine length for main rod ④, see formula and schematic above.
- Loosen positioning nuts ⑤ and compression nuts ⑥.
- Set main rod ④ to length X and block with positioning nuts ⑤.
- Set and block compression nuts ⑥ to a spring height of approx. 10 mm.
- Loosen stop rod nuts ⑧
- Set stop rods ⑦ to approx. 20 mm shorter than the main rod's ④ square end and lock nuts ⑧
- If necessary (due to available space), cut excess rod length

9.4.4 Connecting the MIP Drive Shaft

Connecting to the Housing Drive Port

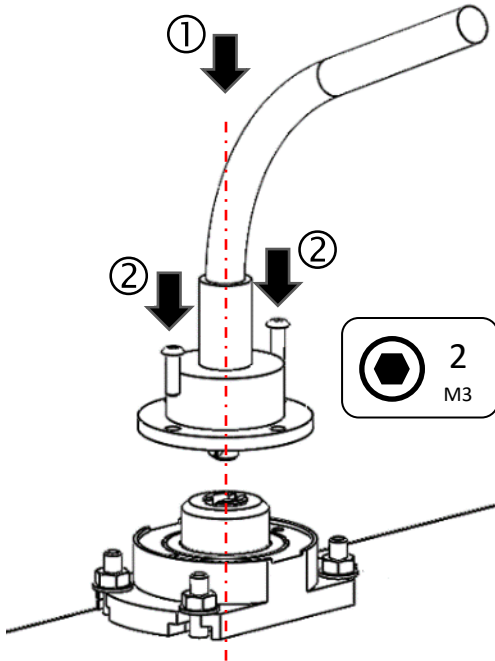

- Insert the shaft end into the housing interface. Note the drive pin is asymmetrical ! Place shorter side to match the setting screw position in the interface hub.

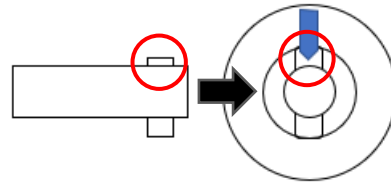

- Fasten with 2 supplied screws.

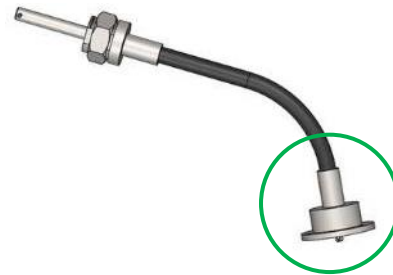

Connecting to the ControlBox Drive Port

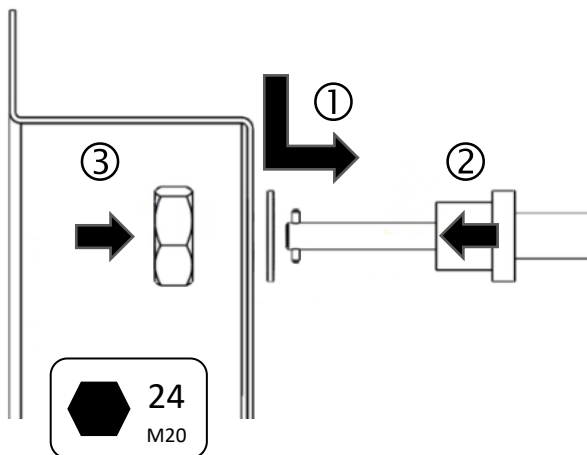

- For best dust- and airtightness, place fiber washer ① before inserting the shaft end ② into the box.
- Fasten with nut ③.

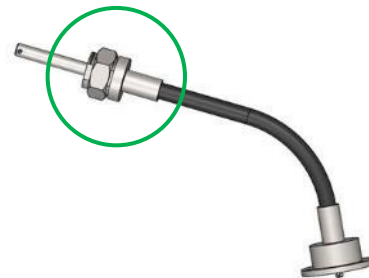

9.4.5 Installing the Control Box

The Control Box can serve a secondary purpose as an access hatch to the technical area in case of intervention on tubing or the flexible drive shaft.

- PLEASE NOTE:** The locking mechanism allows for quick & easy de- and reinstallation, using a radiator key or electric cabinet key or a flat spanner.

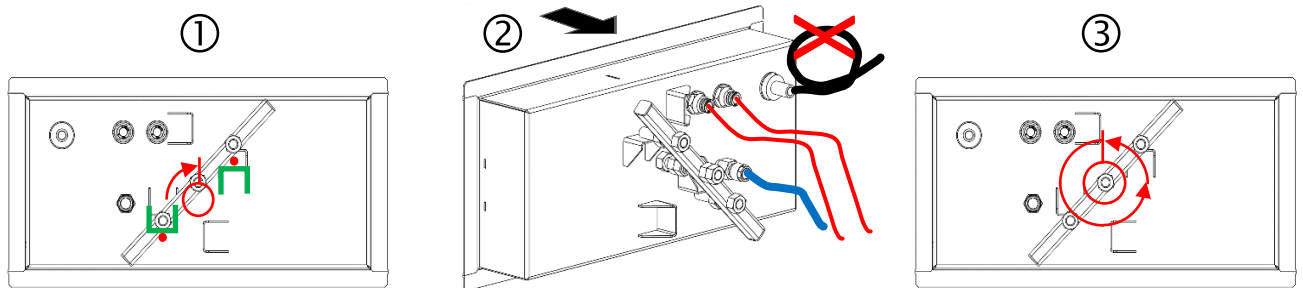

Turn the square locking knob clockwise to the stop, the main rod is now aligned diagonally.

- Insert the box into the cutout.
 - Caution :** In case of excess length of the shaft, **DO NOT** roll it to a coil !
- Turn the center square knob counter-clockwise to the stop. The main rod is now aligned vertically.
- Continue turning the screw counter-clockwise to the desired clamping strength.



- PLEASE NOTE:** The Control Box will ensure dust tight separation between the room and the technical area. In case of airtight installation apply sealant under the flange and around the locking knob.

- PLEASE NOTE:** The actual direction of the probe movement will depend on the housing type and the chosen installation orientation :

- Turn **CLOCKWISE** →
Probe moves **TOWARDS** the drive port
- Turn **COUNTER-CLOCKWISE** →
Probe moves **AWAY** from the drive port
- Apply the provided stickers in a convenient location to signal direction of probe movement to the operator.

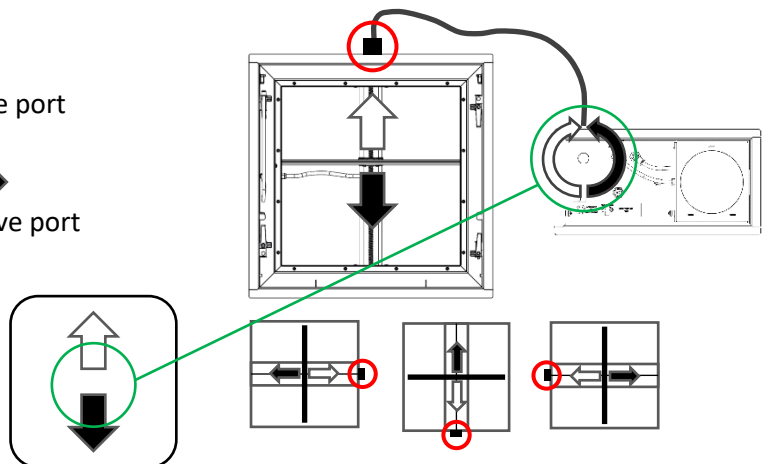

9.4.6 Installation Validation before Startup

△ IMPORTANT: Verify probe state and alignment

The probe will be inaccessible without breaking confinement once the HEPA filter is installed in the housing.

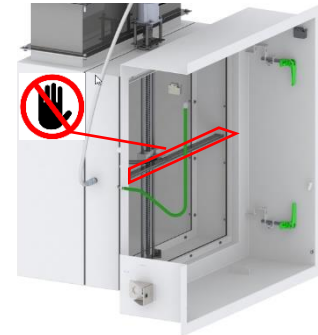

After installation or intervention or after probe removal and re-installation, perform a running test to check :

- Probe movement must be smooth and precise over the full support length.
- End positions must be reached without blockage
- The probe must not touch the module frame in any position (alignment).
- The connection tube must not stretch or collapse at any point, nor exceed the probe level.
- Scan support rails and drive screw must be free from dirt, surface damage or deformation

△ IMPORTANT: Use only the Camfil qualified MIP driver to operate the system (see also § 10.4.7)

DO NOT use general purpose electrical screwdrivers !



Exceeding drive torque will damage the flexishaft and require breaking confinement or access to the technical area for replacement.

△ WARNING: Danger of injury due to improper commissioning and operation



During normal operation, the scanning system will be safely inaccessible behind the installed filter.

During testing without filter after installation or maintenance, use precaution.

- Handle the probe with care.
- Ensure that components are properly assembled and aligned
- Ensure using only qualified drive equipment
- Ensure the entire scanning area is free from obstruction or foreign bodies
- Do not reach into the housing when the system is moving or when a driver is connected to the interface in the box.

10 Operation

10.1 Filter Compatibility

Any CleanSeal housing can be ordered with filter clamps preset for either MD, MX or MG HEPA filter panels (frame heights 66 / 90 / 110 mm), or for 78 mm frame height.

Camfil Ecopleat filters with (recommended) or without gasket at 98 / 96 mm filter height are also compatible with CleanSeal housings. Use settings for MX (90 mm) and adjust, [see § 10.2](#).

Camfil CleanSeal clamping presets are designed for filters with 6 ... 7,5 mm foamed PU gasket.

Other brand filters and/or gasket types may be used, referring to the instructions in [§ 10.2](#), however, this may affect installation integrity. If in doubt, contact your Camfil representative.

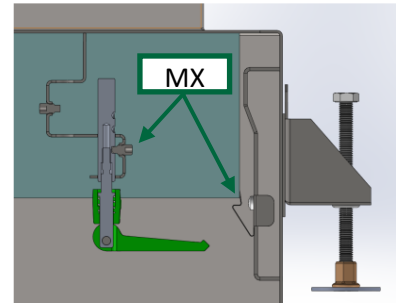

- PLEASE NOTE :** Clamp settings can be changed, so the customer has the option of upgrading to bigger filters for higher airflow or reduced pressure drop at any time, [see § 10.2](#).

Prefilters

CleanSeal Exhaust wall (CR) and ceiling (CL) housings can accept an additional 48 / 50 mm G4 / G5 filter in the optional prefilter door, which can be exchanged against the standard door at any time.

10.1.1 Gel Filter Compatibility

On request, all CleanSeal can be proposed for GEL fluid gaskets as well.

3 filter frame profiles are compatible with CleanSeal Gel filters (frame heights 71 / 105 / 115 mm), corresponding to the 3 presets.

- PLEASE NOTE :** 130 mm frames are NOT compatible with the standard housing chassis.

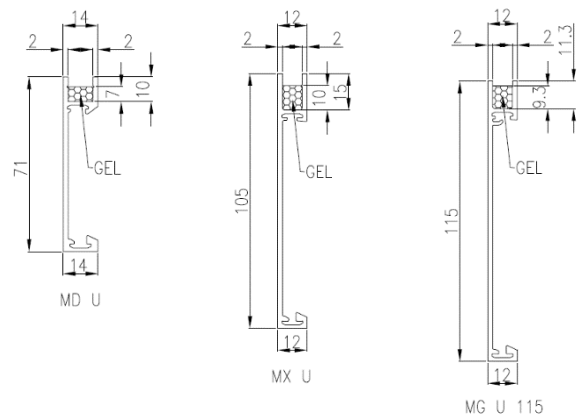

10.2 Filter Clamping - General Settings

CleanSeal housings come out of the box “plug-and-play”, i.e. fully configured to specification.

The scalable filter clamping settings can be changed at any time.

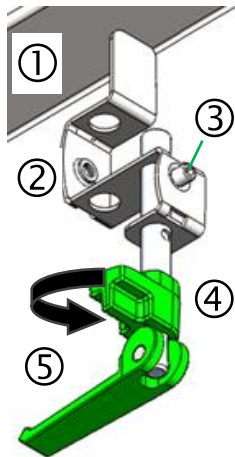

- ① Gasket compression surface
- ② S-bracket
- ③ Setting screw
- ④ Filter clamp (rotating)
- ⑤ Clamping lever

Filter height	Clamp Config. PU	Clamp Config. GEL
MD	A-1	A-1
78	A-2	-
MX	B-1	B-2
MG	B-3	B-3

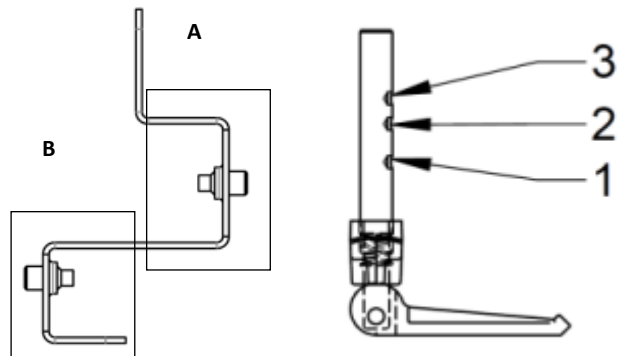

PLEASE NOTE : The retainer height must follow the filter clamp setting (ceiling housings only).

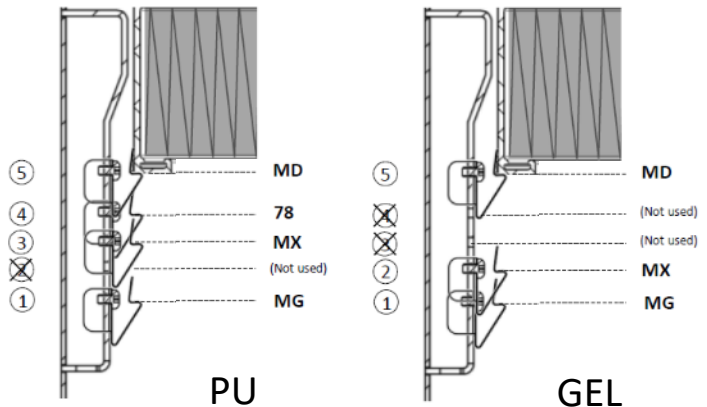

Clamping Height Base Settings

PU Filter Type	Height setting nominal clamp closed h_{PU} [mm]	Range Adjustment		Clamping Height Range	
		+ add compression [turns] / [mm]	- less compression [turns] / [mm]	min [mm]	max [mm]
MD	67,5	+0,5 / 0,5	-13 / -10,5	67	78
78	79,5	+0,5 / 0,5	-13 / -10,5	79	90
MX	91,5	+0,5 / 0,5	-13 / -10,5	91	102
MG	111,5	+0,5 / 0,5	-13 / -10,5	111	122

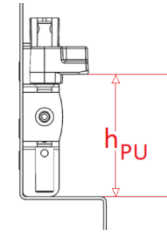

GEL Filter Type	Height setting nominal clamp closed h_{PU} [mm]	Range Adjustment		Clamping Height Range	
		+ add compression [turns] / [mm]	- less compression [turns] / [mm]	min [mm]	max [mm]
MD	71	+5 / 4	-9 / -7	67	78
MX	105	+2,5 / 2	-11 / -9	103	114
MG	115	+5 / 4	-9 / -7	111	122

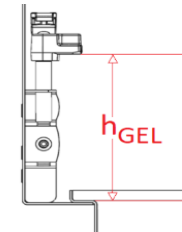

PLEASE NOTE : Clamping height and / or compression can be further adjusted :

- Lift the clamping lever to its vertical position, then
- Turn clockwise for more compression
- Turn counter-clockwise for less compression

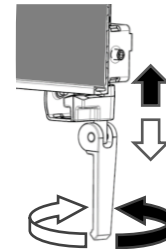

1 turn 360° = +/- 0,8 mm compression

Adjust in half turns, so the closed clamping lever remains always parallel to the housing wall.

10.3 CleanSeal CL for Ceiling Installation

10.3.1 Features

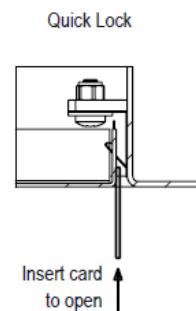
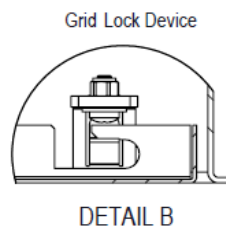
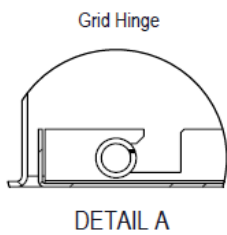
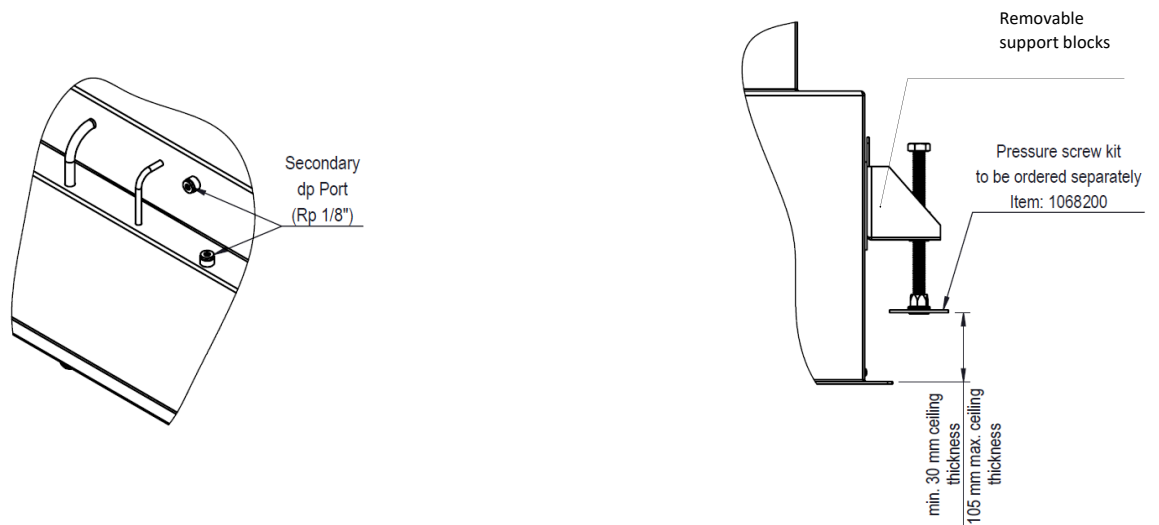
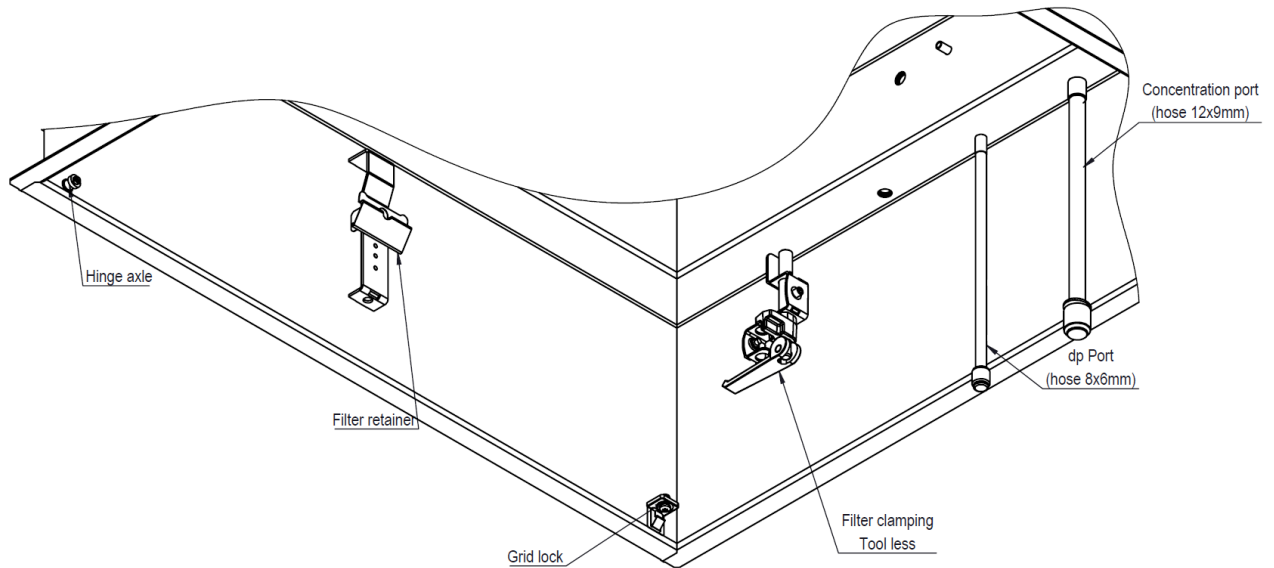

10.3.2 Front Plate Operation for CleanSeal CL

The front plate locking system allows for fast & easy access without tools (no screws).

- To unlock, use the Quick Access Card (included with each housing) or any other plastic blade $\leq 2\text{mm}$

DO NOT use a metal tool as you might scratch the coating and thus compromise corrosion protection.

- To lock, simply close the front plate.
- 100% safe lock against accidental opening (e.g. during cleaning).

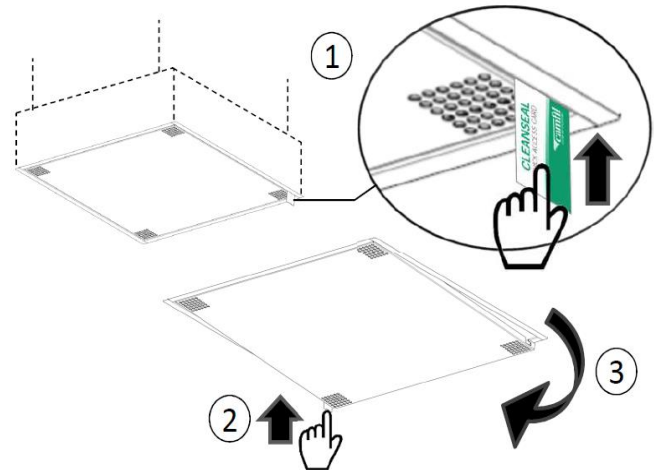

- PLEASE NOTE:** For revalidation of the filter, the front plate can stay in place. However, we recommend taking it out for filter change. Removing or installing the front plates requires full 90° opening. A minimum intervention space beneath the housing needs to be free from obstructions of any kind. Custom solutions are available if this cannot be ensured.

→ Please contact your Camfil representative

To remove open 90° and LIFT to unhook

		Minimum Intervention Space [mm]	
		Short Side (SS) down	Long Side (LS) down
CleanSeal Sizes	3P3	327	
	3P6	327	632
	4P4	508	
	5P5	530	
	6P6	632	
	9P6	632	937
	9P9	937	
	11P5	530	1130
	12P6	632	1242

- PLEASE NOTE:** Front Plates are fully interchangeable between different models.

10.3.3 Filter Installation / Exchange

CAUTION:



The media pack of a traditional HEPA filter panel is extremely sensitive. This is no longer an issue for latest generation filters like Camfil EnerGuard®, but generally speaking, filters have to be handled with the utmost care to avoid creating damage during installation.

DO NOT place objects on or manipulate filter panels by touching the media, even for panels with protective grid.

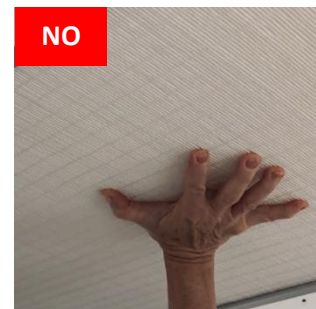

Handle filter panels by the frame only !

The features of the CleanSeal toolless filter clamping system support safe and easy filter change.

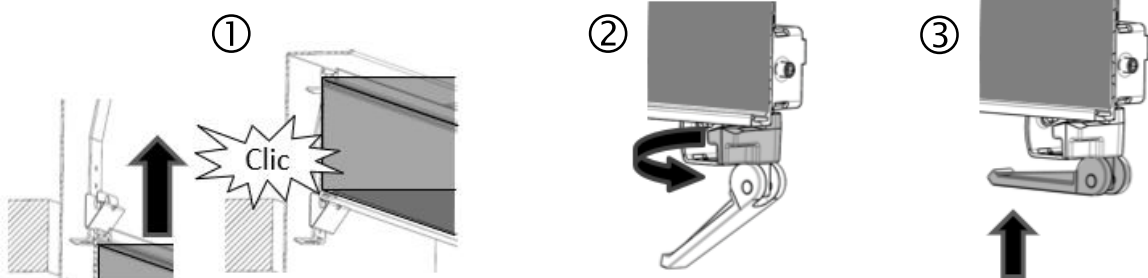

- Before inserting the filter, make sure all clamping blocks are rotated parallel to the housing wall.
- Insert the filter into the housing and push up, until the retainer springs lock with a distinct click. The filter is now safely maintained, clamps may be operated with both hands free.
- Rotate the clamps out over the filter and close clamping levers.
- For filter deinstallation, proceed in reverse order. Push on retainer springs to release the filter.

PLEASE NOTE: Clamping settings will be stable over time, unless clamping levers get rotated inadvertently. Settings are adjustable, [see § 10.2](#).

CAUTION: In case of integrity issues at installation, check all possible root causes. **DO NOT overcompress filter gaskets, as damage might result.**

10.3.4 Local Aerosol Injection with IntegriPod

For aerosol requirements with respect to the airflow, please refer to ISO 14644-3 or other applicable standard. The IntegriPod insert in the upstream duct will allow to comply with or exceed ISO 14644-3 particle distribution performance requirements. On Integrity or custom housings, a local injection port is accessible in the filter chasis of the housing.

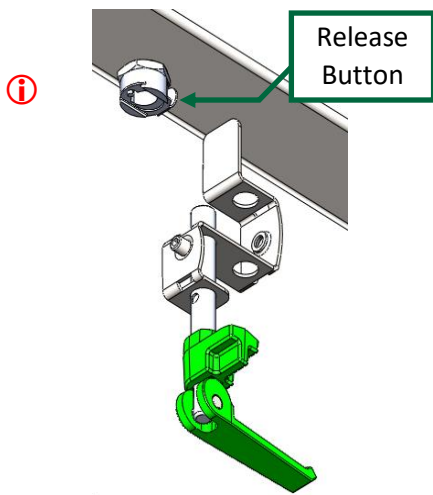

PLEASE NOTE: Space inside the CleanSeal housing is restricted and access to the injection port fitting can be difficult for hookup and release of the injection line, especially with MX or MG filters. This can be addressed with the hookup fitting mounted on a tube and a plastic rod for operating the release button.

For superior ease of use, a hookup tool is available.

Hookup tool 1072227

➔ Please contact your Camfil representative

Using the Hookup-Tool

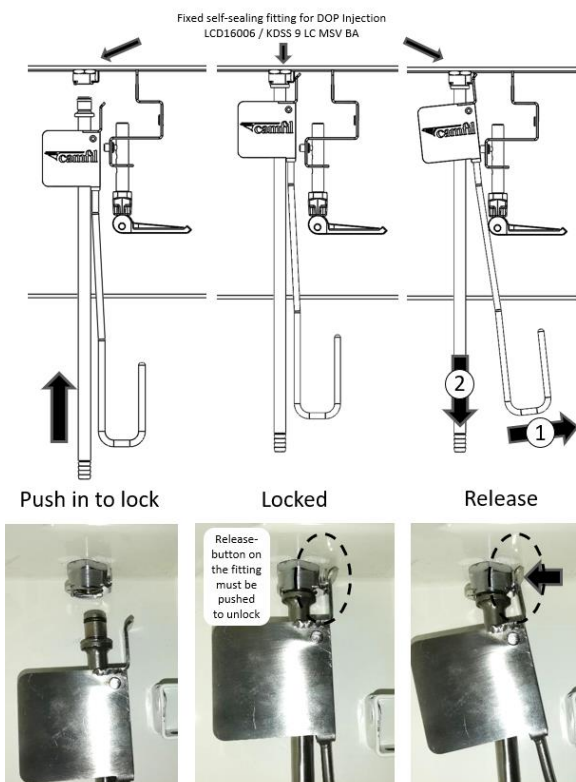

➔ The tool cannot be inserted the wrong way, due to a safety key :



➔ The injection fitting is self-sealing and will only lock and open, once the O-ring on the tool's tip has sealed the connection

➔ Check condition of the O-ring before using the HookUp-Tool, replace if necessary.

➔ 2 spare O-rings are packed with the tool

For further spare O-rings use
O-ring DIN3770 - 7,5 x 1,8 NBR70

10.3.5 Controlling Multiple Housings with IntegriBox

IntegriBox will allow remote aerosol injection and upstream pressure readings for up to 5 (10) housings.

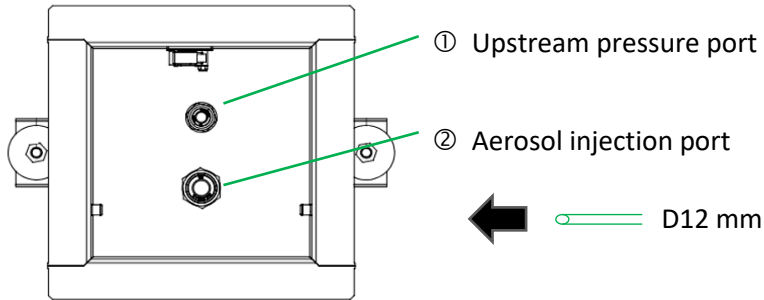

- Connect the “+” port of the manometer to the relevant upstream pressure port for a pressure drop reading against the ambient room pressure.

PLEASE NOTE: The box for technical areas features an additional pressure port for remote readout of the downstream room pressure

- Connect an aerosol generator to the injection port ② using a D12 tube compatible with quick-connect fittings. Push the locking ring on the fitting to release.

PLEASE NOTE: Make sure the capacity of your generator is sufficient to compensate for the particle loss, function of the injection tube length.

Particle injection loss for DEHS

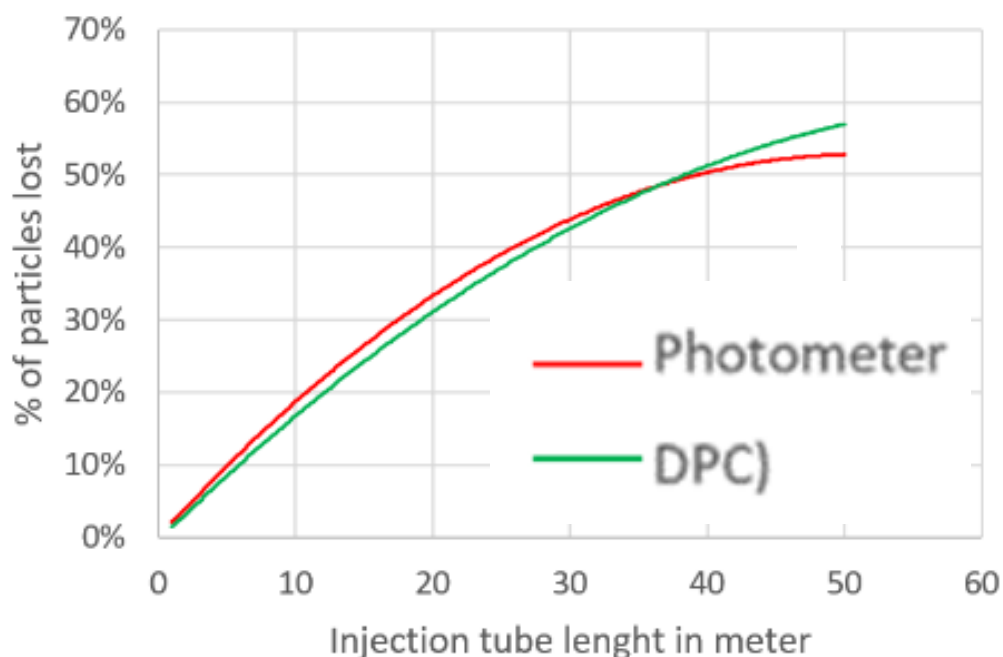

10.3.6 Filter Validation for Supply Air

- Connect a particle counter or photometer with dilution stage to the concentration port in the housing.
- Connect an aerosol generator to the injection port in the housing **or** in the IntegriBox.
Caution When using the port in the housing, switch off the particle counter before disconnecting as the port seals airtight automatically!
- Upstream pressure may be monitored in parallel, using the dp-port in the housing **and / or** in the IntegriBox.
- Use your sampling device to scan the filter manually, referring to applicable standards.



10.3.7 Filter Validation for Extract Air

For exhaust housings, please refer to the following chapters:

- ➔ For aerosol injection with Testing Shroud, [see § 10.4.5.](#)
- ➔ For filter validation with Mobile Integrity Probe, [see § 10.4.6.](#)

10.4 CleanSeal Exhaust CR for Wall Installation

10.4.1 Features

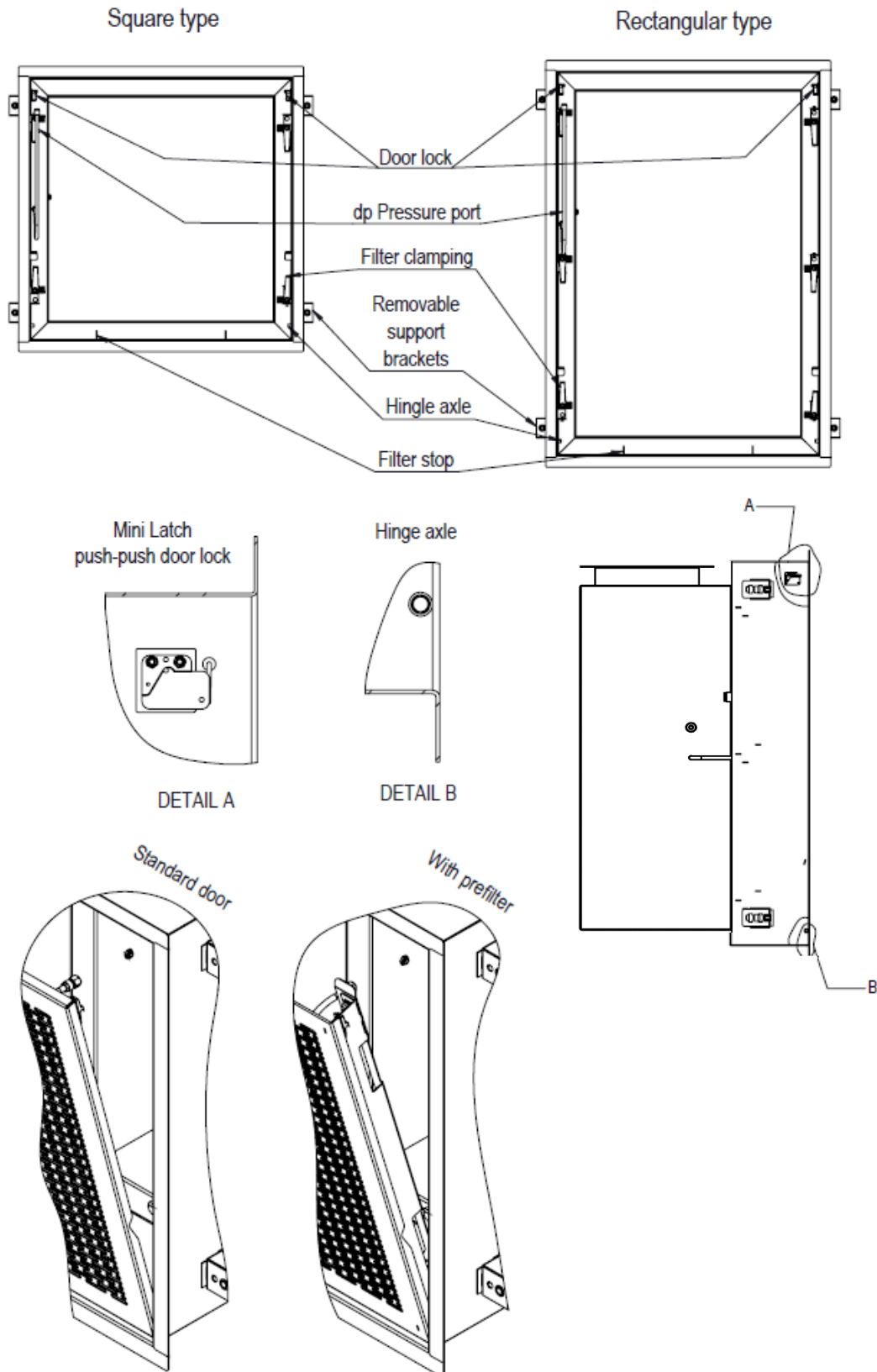

10.4.2 Door Operation for CleanSeal Exhaust CR

The door locking system allows for fast & easy access without any tools.

- To unlock, push on both corners of the housing door
The door unlocks with an audible "click" for each lock.
- The door will open to a stop. From this position
 - The HEPA dp-port is accessible in its storage clamps
 - The prefilter can be changed without holding the door
 - The door can be lifted out for access to the HEPA filter
- To lock, push again on both corners of the housing door.
The door locks with an audible "click" for each lock.

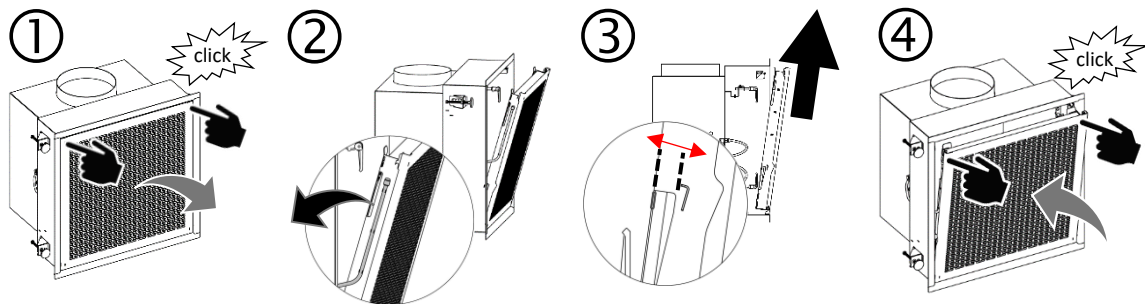
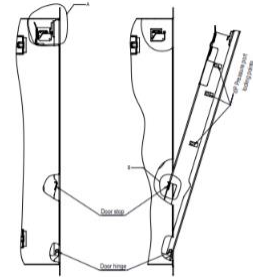

PLEASE NOTE: For installation of the door, access to filters, or any other intervention on the housing, a minimum intervention space in front of the housing needs to be free from obstructions of any kind.

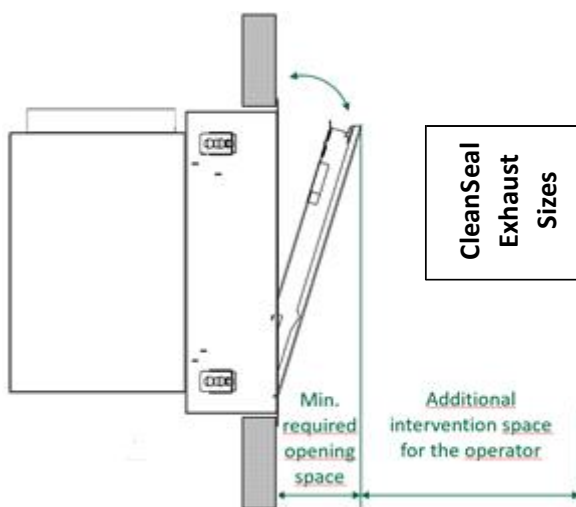

		Minimum Intervention Space [mm]		
		Door	Operator	Recommended
CleanSeal Exhaust Sizes	3P3	127	600	800
	3P6	181		800
	6P6	181		800
	9P6	266		900

PLEASE NOTE: CleanSeal Exhaust wall housings (CR) can be fitted with different doors - with or without prefilter - to suit different requirements.

A standard door can be replaced by a prefilter door at any time.

10.4.3 Main Filter Installation / Exchange

⚠ CAUTION: The media pack of a traditional HEPA filter panel is extremely sensitive. This is no longer an issue for latest generation filters like Camfil EnerGuard®, but generally speaking, filters have to be handled with the utmost care to avoid creating damage during installation.

DO NOT place objects on or manipulate filter panels by touching the media, even for panels with protective grid.

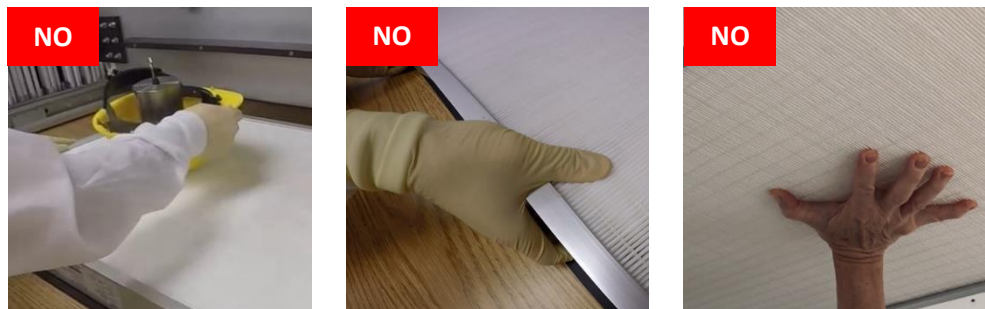

Handle filter panels by the frame only !

The features of the CleanSeal toolless filter clamping system support safe and easy filter change.

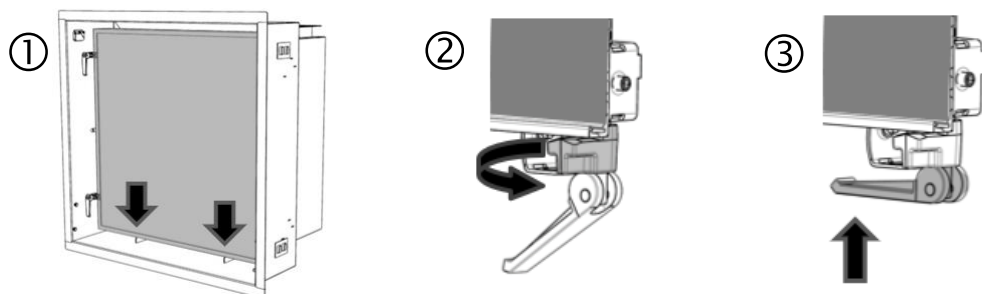

- For best scanning results **with MIP housings, orient filter with media pleats parallel to the probe**
- Before inserting the filter, make sure all clamping blocks are rotated parallel to the housing wall.
- Place the filter into the housing on the support rails.
- Rotate the clamps out over the filter and close clamping levers.
- For filter deinstallation, proceed in reverse order.

ⓘ PLEASE NOTE: Clamping settings will be stable over time, unless clamping levers get rotated inadvertently. Settings are adjustable, [see § 10.2](#).

⚠ CAUTION: In case of integrity issues at installation, check all possible root causes. **DO NOT overcompress filter gaskets, as gasket damage might result.**

Clamping lever position

When combining a **MG-size** HEPA filter with a prefilter-door, respect the following clamping lever positions to avoid collision :

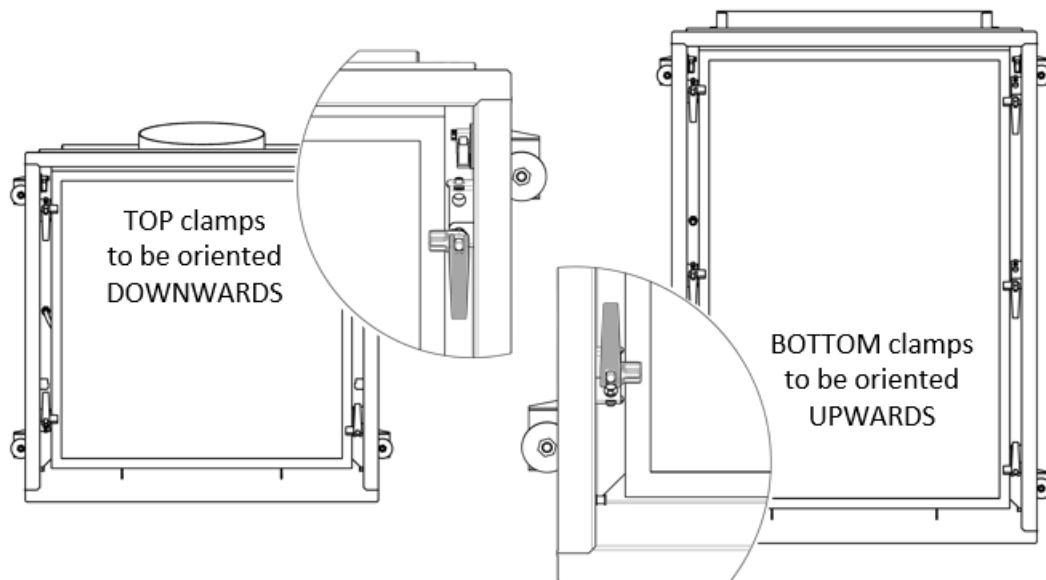

10.4.4 Prefilter Installation / Exchange

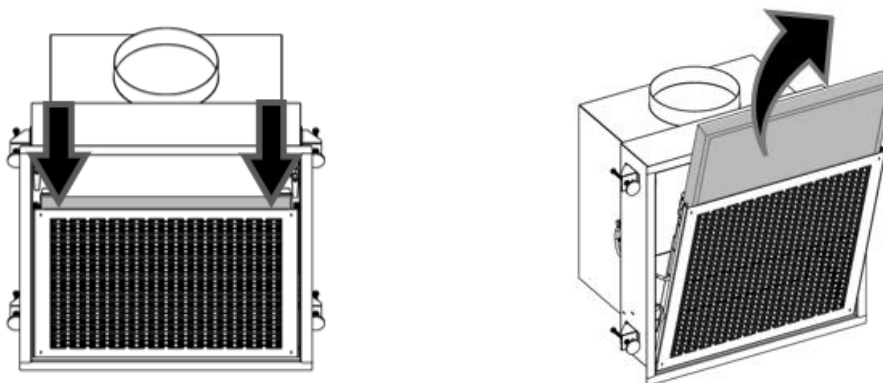

- Before inserting the filter, make sure all spring clamps are mobile in their holders.
- Insert prefilter into the slot and push all the way down.
The filter is now safely maintained, pressed against the door surface by the springs.
No gasket required for G4/M5 filter grades.
- For filter deinstallation, seize the prefilter by its frame and pull up.

10.4.5 Testing Shroud (Option)

The separately available testing shroud is a compact unit that will allow for aerosol distribution compliant with or exceeding distribution performance requirements of IEST-RP-CC034.4 / ISO14644-3 for HEPA filter validation purposes.

➔ A comprehensive testing report on particle distribution performance is available, upon request.

PLEASE NOTE: The universal testing shroud module is complemented by a mounting frame for either CR wall- or CL ceiling-installed housings.

The actual shroud module latches on to the frame with toolless clamps.

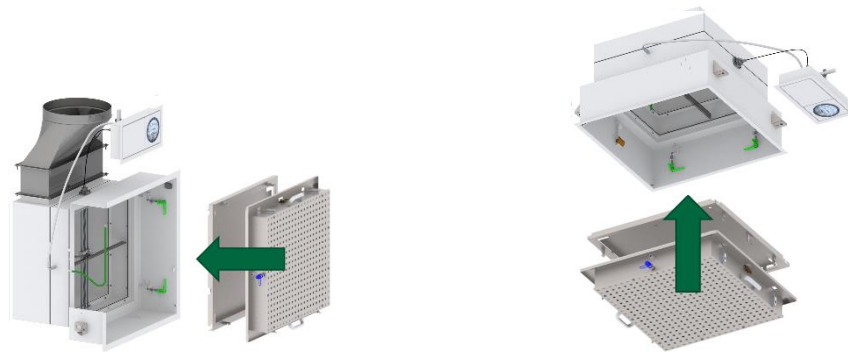

Upstream view

Downstream view

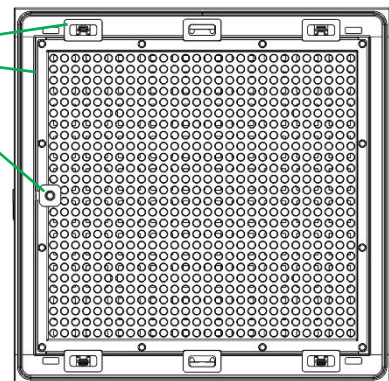
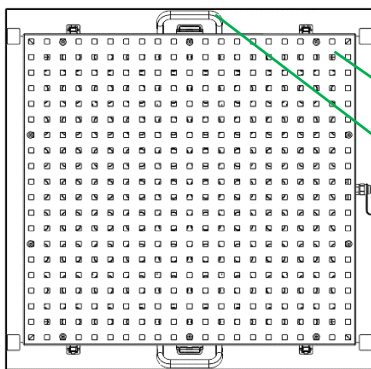

- ① Shroud gaskets
- ② Protective grid
- ③ Transport handles

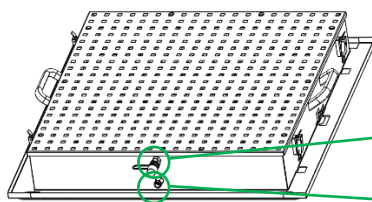

- ④ 100% concentration port
- ⑤ Injection port

Installing the Testing Shroud

- Replace frontplate or door by the respective mounting frame with diffuser plate.
 - The wall mounting frame is operated like CleanSeal Exhaust (CR) doors, [see § 10.4.2](#). It features 4 locking hooks ①.
 - The ceiling mounting frame is operated like CleanSeal (CL) front plates, [see § 10.4.2](#). It features 4 locking hooks ① and 2 safety hooks ②.
 - Insert long dp port tubes (for prefilter doors) into clamps ③ on the mounting frame to avoid damage to the tube, the MIP system and/or the filter during manipulation

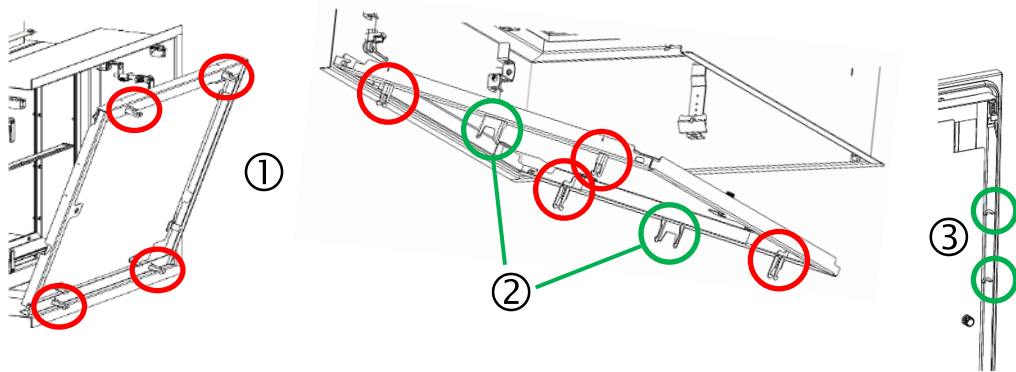

- Before installing the shroud, make sure its gaskets are in good condition
- **For wall housings**, slip shroud onto the 4 locking hooks and close 4 shroud latches

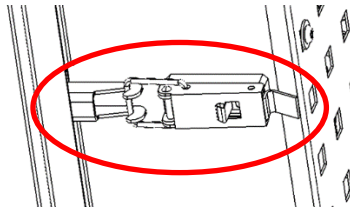

- **For ceiling housings**, slip shroud onto the 4 locking hooks and and push up, until the 2 safety springs close with a distinct click. The shroud is now safely maintained, latches may be operated with both hands free. Close 4 shroud latches, making sure their safety spring locks properly.

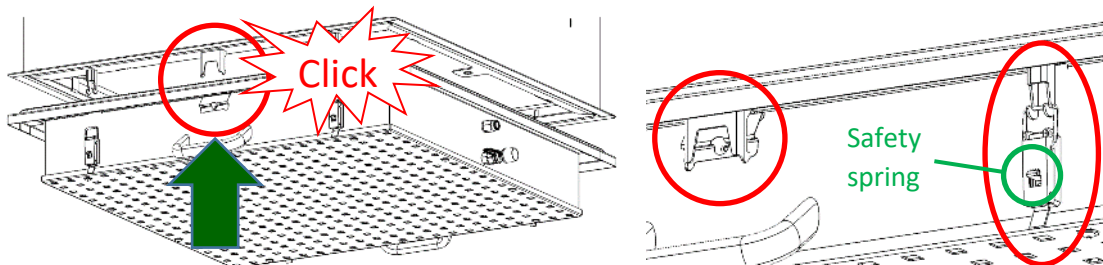

⚠ WARNING: Danger of injury due to falling objects

The shroud module weighs up to 10 kg (format dependent). Improper handling can result in severe injury and property damage. When manipulating the shroud, make sure that you have a firm grip on the handles and that all safety devices properly engage.

- Connect a particle counter or photometer with dilution stage to the concentration port using a D10 tube compatible with quick-connect fittings. Push the locking ring on the fitting to release.
- Connect an aerosol generator to the injection port using G1/4 fittings RIEGLER 246.32 or 246.12 or compatible. Pull back the locking ring on the fitting to release.

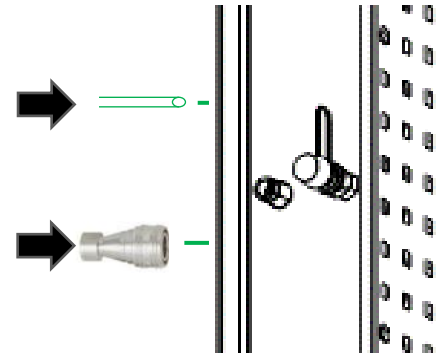

Removing the Testing Shroud

- Disconnect tubes from testing devices
 - ① Push the safety spring on the latches and
 - ② lift the latch to unlock

Make sure that the shroud safety springs remain engaged before taking your hands off !

 - ③ For ceiling housings, grip the shroud by the handles, take the weight and compress the safety springs to
 - ④ Disengage the shroud

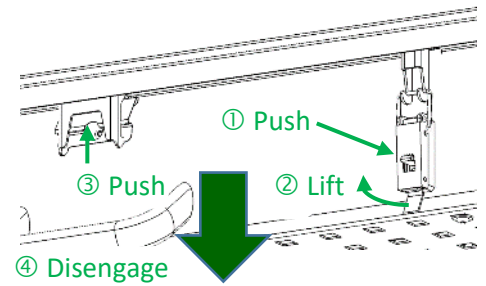

⚠ WARNING: Danger of injury due to falling objects

The shroud module weighs up to 10 kg (format dependent). Improper handling can result in severe injury and property damage. When manipulating the shroud, make sure that all safety devices properly engage and that you follow above instructions.

- Replace mounting frame with housing frontplate or door.

10.4.6 Filter Validation with Mobile Integrity Probe

The Mobile Integrity Probe (MIP) is a manual scanning system for for HEPA filter validation purposes in exhaust air applications, integrated downstream into the housing, [see also § 9.4](#)

- ➔ A comprehensive testing report on system performance is available, upon request.
- ➔ For scanning speed and sampling rates with respect to the airflow, please refer to ISO 14644-3 or other applicable standard.
- For reliable results and an ISO 14644-3 compliant aerosol distribution, we recommend using the Camfil Testing Shroud, [see § 10.4.5](#). This accessory integrates aerosol injection and upstream concentration ports.
- The downstream sampling port and control of the probe are located in the Control Box, [see § 9.4.1](#).

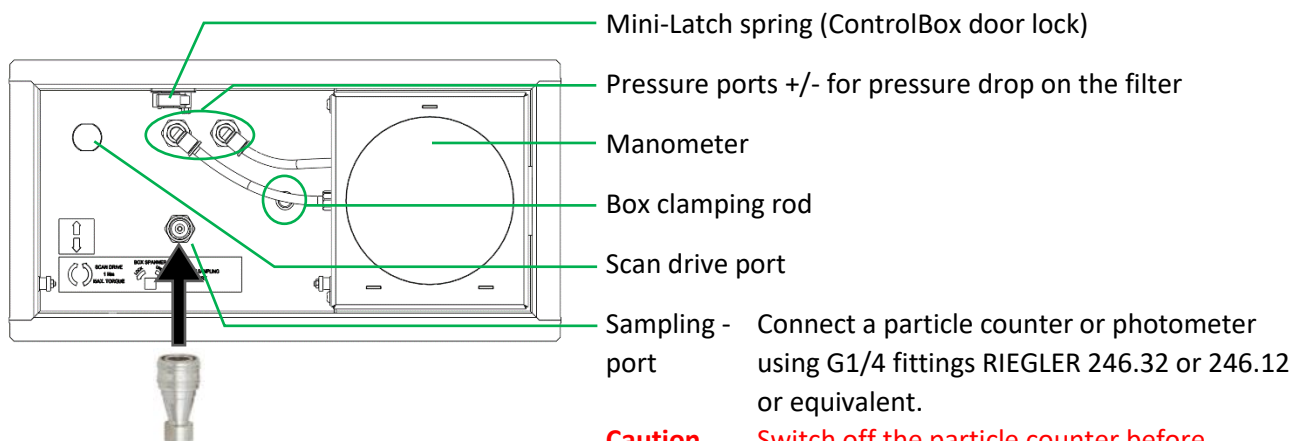

Caution Switch off the particle counter before disconnecting as the port seals airtight

- The Control Box door may remain in place to deposit small parts or it may be taken off before operation, if necessary.

△ IMPORTANT: Use only the Camfil qualified MIP driver to operate the system ([see also § 10.4.7](#))

DO NOT use general purpose electrical screwdrivers !

Exceeding drive torque will damage the flexishaft and require breaking confinement or access to the technical area for replacement.

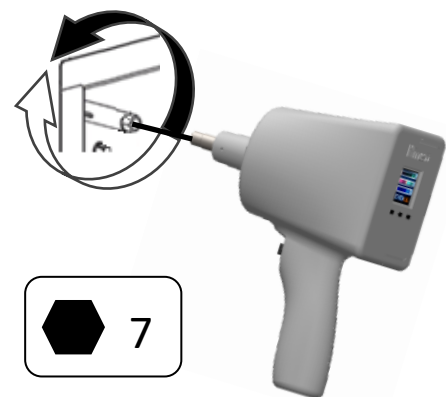

- PLEASE NOTE:** The actual direction of the probe movement will depend on the housing type and the chosen installation orientation. Refer to the sticker applied on installation for practical operator orientation, [see § 9.4.5](#) :

Generally :

- Turn **CLOCKWISE** Probe moves **TOWARDS** the drive port
- Turn **COUNTER-CLOCKWISE** Probe moves **AWAY** from the drive port

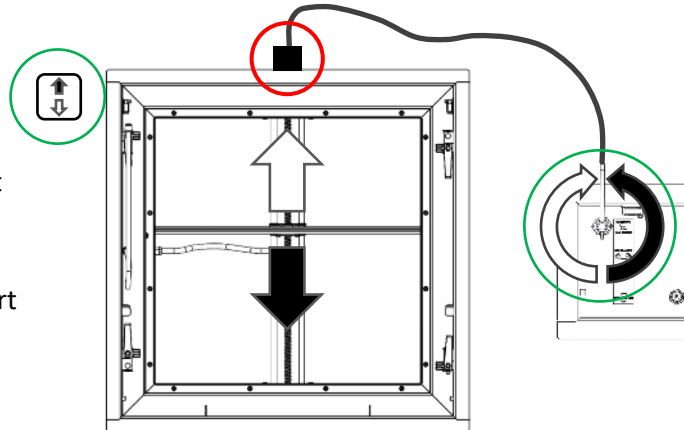

- CAUTION:**
When using a manual crank, turn lightly and regularly, **DO NOT** force!
When using a power tool, limit drive torque to 1 Nm to avoid damaging the drive shaft in the end positions.

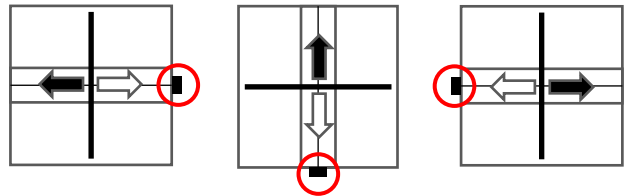

A damaged drive shaft may be replaced without compromising the housing or filter installation, using the Control Box as an access hatch, [see § 9.4.1](#) and [§ 9.4.5](#).

- PLEASE NOTE:** The necessary rotational drive port speed R for any required “scanning” speed V_s (sampling probe displacement) is calculated as follows :

$$R [rpm] = V_s \left[\frac{mm}{s} \right] \times 20 \quad (\text{e.g.: } V_s = 10 \text{ mm/s} \rightarrow R = 200 \text{ rpm})$$

Drive tools for MIP operation can be obtained from Camfil.

➔ Power tool **MIP Driver** **Ref. 1086894**



10.4.7 MIP Driver

The Camfil MIP Driver is designed to enable simple operation in a wide range of stable scanning speeds while preserving the drive mechanism.

Power Supply is delivered from a main adapter or alternatively by a optional portable battery pack.

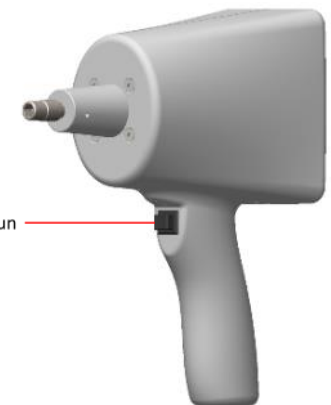

User Interface :

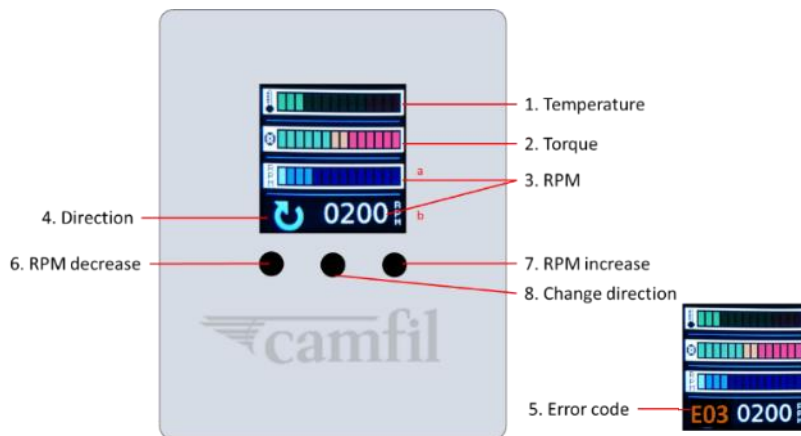

Display and Buttons

1. Temperature (maximum from motor and driving circuit) is linearly visualized from 15°C (0 bars) to 60°C (14 bars)
2. Torque is linearly visualized from 0 Nm (0 bars) to 0,6 Nm (14 bars)
3.
 - a) Preset RPM is visualized as 100 x (bar count + 1). When running actual RPM is highlighted
 - b) Numeric value of the preset RPM value
4. Spindle rotation direction as seen from the back (operator's view)
5. Error code (shared position with rotation direction)
6. Decrease RPM by 100 - adjustable on the run
7. Increase RPM by 100 - adjustable on the run
8. Change rotation direction - only when stopped
9. Run

Operation

1. Set desired rotation speed by using Increase (7) and Decrease (6) RPM buttons.
2. Set desired rotation direction by using button for direction change (8)
3. Start motor operation by pressing run button (9). To stop motor operation, release Run button.
4. Any error code will stop the motor. To reset, press Run button (9) or Direction button (8).

Error Codes

- E01 – Power supply under-volt
- E02 – Maximum torque reached (> 0,9 Nm - indicates a mechanical blockage)
- E03 – Critical torque reached (> 0,65 Nm for 80 ms - indicates a friction issue)
- E04 – Power supply over-current
- E05 – Driver circuit over-temperature
- E06 – Motor over-temperature
- E07 – Internal error

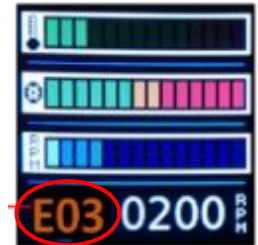

Any error code cause motor to stop operation. To reset, press Run button (9) or Direction button (8).

The Camfil MIP Driver is delivered with its power supply in a transport case.

MIP Driver Ref. 1086894



The case can additionally hold the optional Battery Pack with charger (not included, to be ordered separately) .

Battery Pack Ref. 1086908

















11 Maintenance

CleanSeal Terminal housings don't require regular maintenance interventions

For best long-term performance, the **following checks are recommended when changing filters** :

- Check the gasket sealing surface.
If necessary, clean with alcohol on a soft, lint-free cloth.
- Check condition and firm connection of the measurement port PU tubes.
Aged and/or hardened tubes should be replaced by a new tube (ca. 200mm long)
- When installing a new filter, check gasket compression.
If necessary, you may adjust by turning the unlocked green clamp handle, [see § 10.2](#).
- On MIP housings check absence of filings etc. which would indicate a mechanical issue with excessive wear on the scan drive.
- For specific intervention procedures, [see § 11.2](#)
or contact your Camfil representative.

11.1 Spare Parts

Category	Designation	Illustration	Camfil COMIC
	PU Air Tubing for dp ports green D8d6		1076242
	PU Air Tubing for 100% ports green D10d8		1071603
	PU Air Tubing for aerosol injection transp. D11.6d9		1076240
	Silicone Sampling Tubing for MIP transp. D10d6		1076271
	Clip for dp ports		1071743
Filter Clamping	Filter Clamp		1068374
	Retainer Spring		1072230
Grid Interface	Front Plate Hinge Pin		1084526
	Front Plate Locking Spring		1072229
	Prefilter Spring		1072234
	Mini-Latch + Hook		1068177
Housing Support	Pressure Screw Kit for Standard Supports "Option B"		1068200
	Compression mounting brackets for ceiling panels 120-165 mm		1072224
	Compression mounting kit for ceiling panels 120-165 mm		1072225
Tools	Camfil Card		1072238
Damper Housing	Damper Adapter Rod		1068197
	Plug for Access to Damper Adapter Rod		1076086
MIP	MIP Drive Flexible Shaft Standard 700 mm		1076031
	MIP Drive Flexible Shaft Standard 1000 mm		1076032
	MIP Driver		1076035
	Battery Pack for MIP Driver		1086908

11.2 Procedures

11.2.1 Replacing Measurement Port Tubes

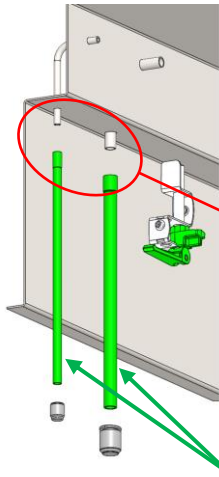

**For CleanSeal
Supply air or
Exhaust air
ceiling housings:**

ca. 200 mm

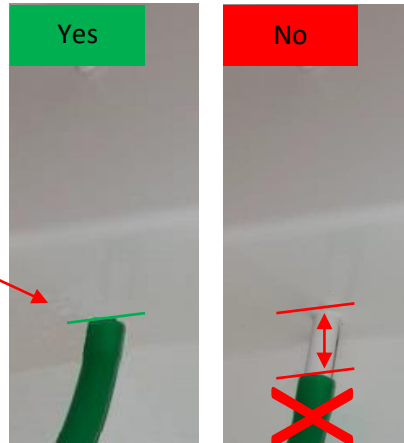

Push PU tube **all the way**
onto the welded steel tube !
(tube may be fully painted)

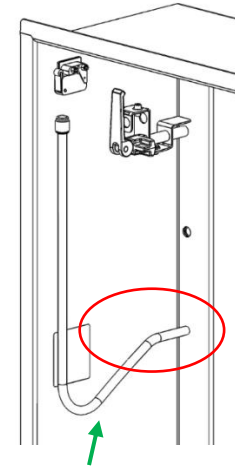

**For CleanSeal
Exhaust air
wall housings:**

Housing Size	L
3P3	450 mm
3P6	490 mm
6P6	490 mm
9P6	540 mm

11.2.2 Adjusting Door Fit on CleanSeal Exhaust

The door should lock safely and easily and should be flush with the housing front when locked. If necessary, this can be readjusted independently for both locks.

△ PLEASE NOTE: In case of door misalignment, check hinge pin bushings first, before touching locks.

- For door alignment
- For a safe lock without friction
- Adjust the mini-latch in the housing.
- Adjust the hook position in the door.

Adjusting door alignment

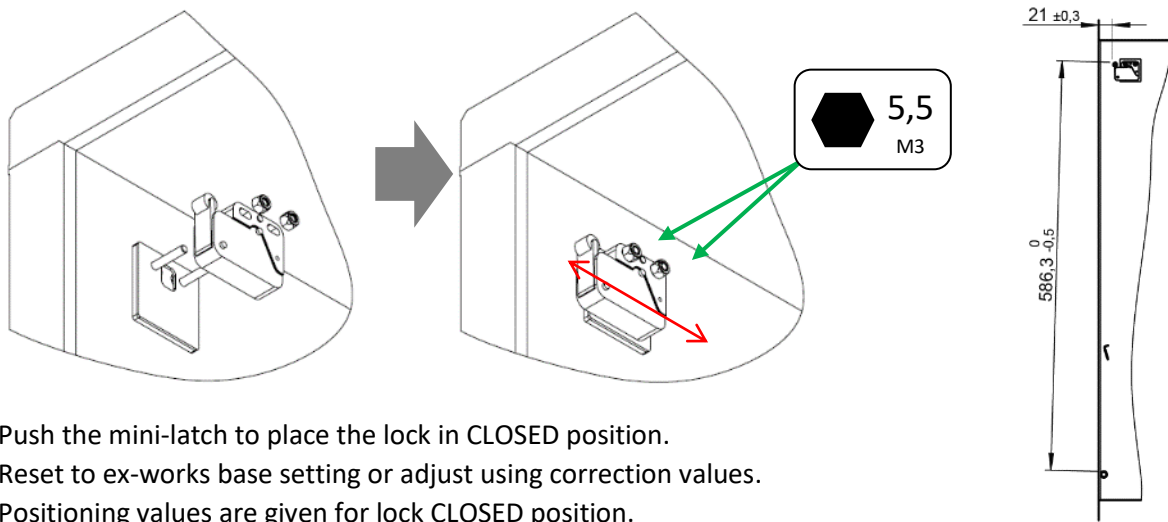

Push the mini-latch to place the lock in CLOSED position. Reset to ex-works base setting or adjust using correction values. Positioning values are given for lock CLOSED position.

Adjusting locking

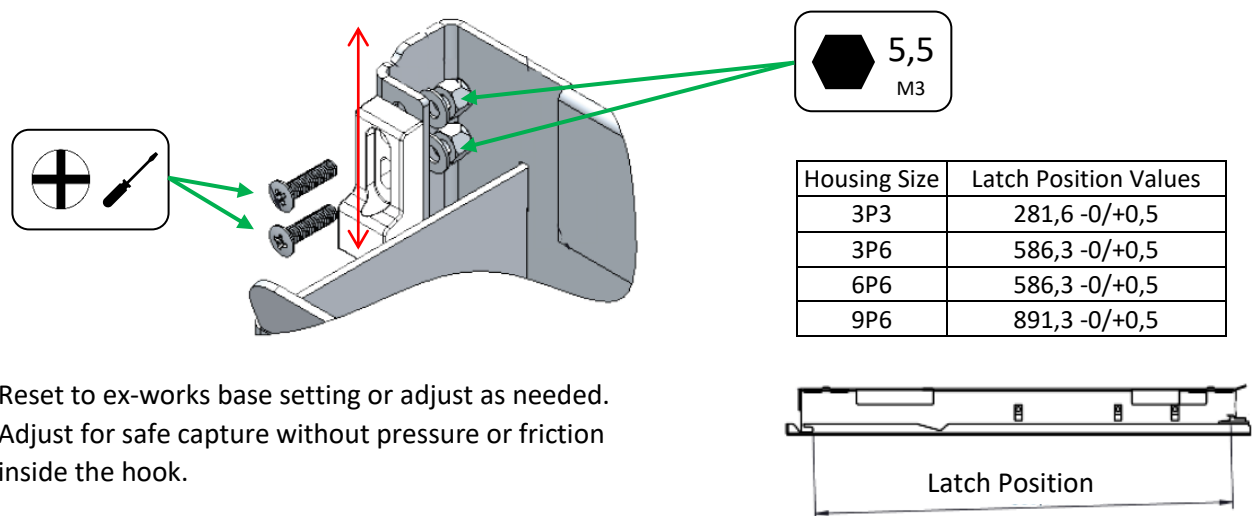

Reset to ex-works base setting or adjust as needed. Adjust for safe capture without pressure or friction inside the hook.