A large, 3D-rendered gas turbine filter unit, shown in a perspective view. It has a green frame and several vertical filter elements. The filter is set against a background of a blue sky with white clouds and a lightning bolt, and a dark blue ocean with white waves.

**CamGT gas turbine filters
– for premium engine protection**

Clean air solutions for turbomachinery

LOOKING FOR A HIGH-QUALITY FILTER? HERE'S YOUR SOLID CHOICE

Introduced more than a decade ago, and found in a large number of gas turbine applications around the world, CamGT has become a trendsetter in the industry. Now, to meet increasing demands for performance and power output, we have upgraded the CamGT with a new solid, airtight frame (4V-300) and a new technique for fixing the media to the frame, the double-sealing design.

The result is a high-performing filter that eliminates bypass air, provides higher power output, extends turbine life, and reduces maintenance and lifecycle costs. Furthermore, each filter grade is individually optimized in order to provide lowest possible pressure drop.

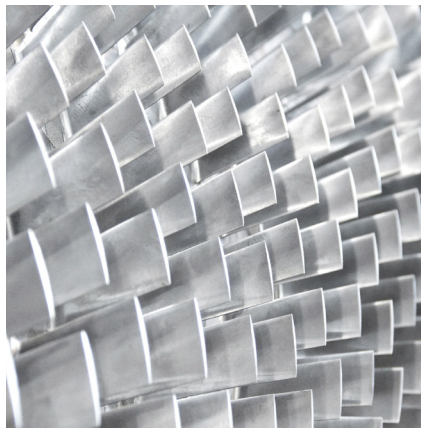

CamGT – premium engine protection that wins in the long run.

Solid frame made from ABS plastic

Grid that keeps the filter from deforming and burst under high air pressure

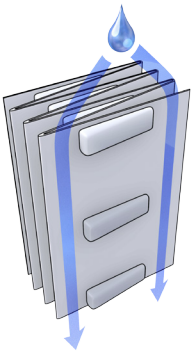

Channels for efficient water drainage

Optimized filter area

Double sealing that eliminates bypass

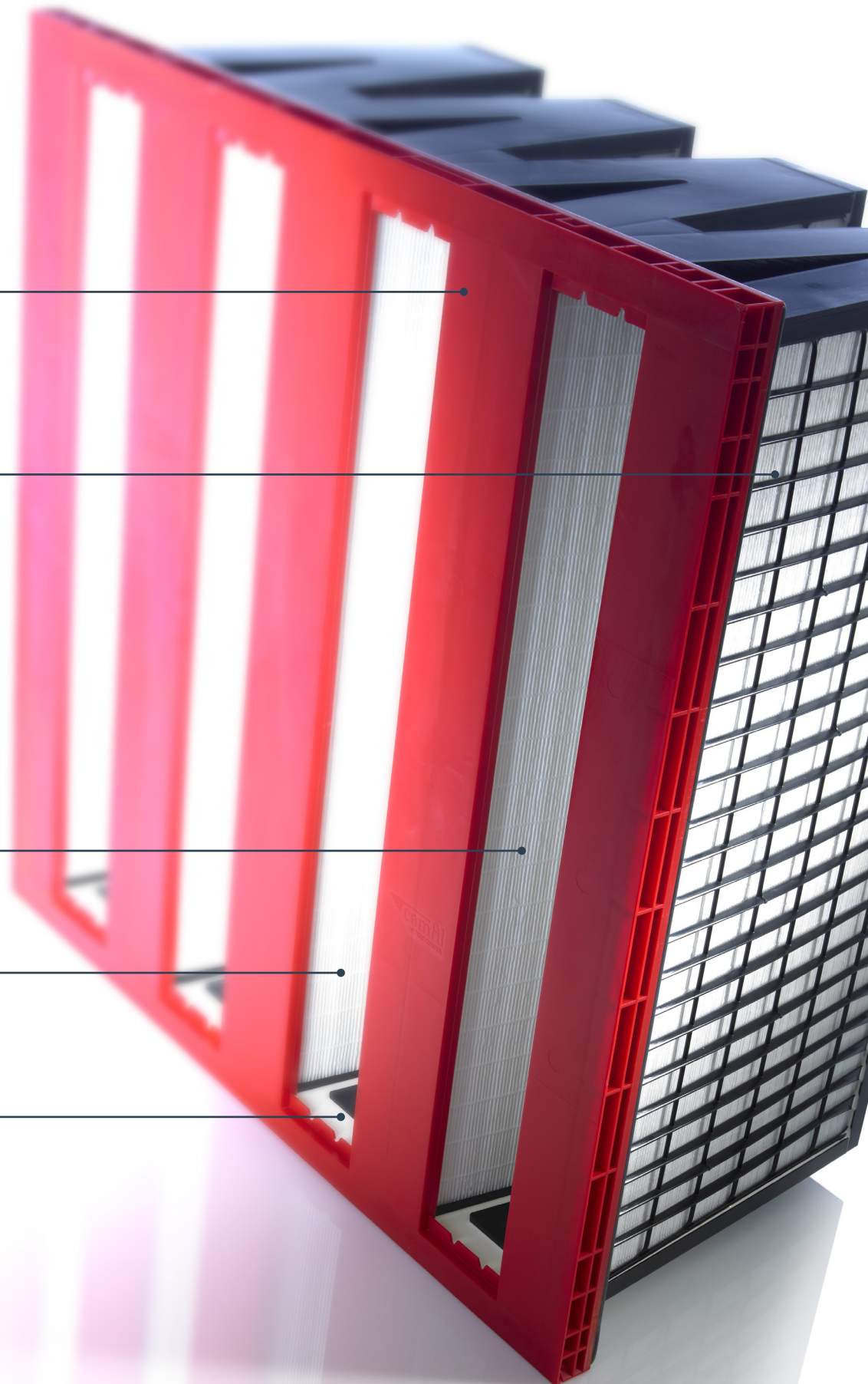



NEW CamGT REDEFINES FILTRATION: SAYS BYE-BYE TO BYPASS

Clean air is vital to all combustion processes. And the prime function of an inlet filter system is to protect the gas turbine from pollutants in the inlet air. Particles entering the gas turbine can cause erosion, corrosion and fouling of the turbine internals.

Erosion is a permanent degradation, mainly caused by relatively coarse particles, above $5\ \mu\text{m}$ in size while corrosion is caused by the entrance of salt which in combination with sulphur in the fuel and high temperature cause hot gas corrosion in the the power turbine. Smaller particles in the sub-micron size cause fouling of turbine blades that change the shape of the rotating and stationary vanes of the compressor and rapidly reduce performance. A secondary effect of fouling is an increase in airfoil temperatures, as fouling in the internal vane

and blade cooling passages reduces heat transfer effectiveness, and ultimately reduces the life of the hot section.

Effective capture of small particulate and airborne salt is therefore of vital importance for long and efficient operation. If not removed by the inlet air filtration system, the particle injection will force the operator to frequently water wash the compressor either by temporary on-line washing or more efficiently and costly during shut down.

What is bypass?

A common problem in gas turbine air filtration is bypass air, a condition where air flows through the system without passing through the filter media. Bypass occurs when filter media is not properly sealed in the filter frame or when filters

are not properly installed and gasketed in filter racks.

Gas turbines are often located in harsh environments and filters are exposed to high velocity winds in combination with air fluctuations. If the media is not securely bonded to a solid frame there is a risk for the media to bulge and even burst.

Leakages between the frame and the media allow unfiltered air to enter the turbine and bring harmful coarse particles causing corrosion and blade fouling. This will increase operating costs through inefficient operation and increased maintenance.

KEY BENEFITS

- Ensures efficient water drainage
- High filtration efficiency
- Low pressure drop also in wet conditions
- Resistant to turbulence and high pressure drops
- Reduced environmental impact

USER BENEFITS

- Less maintenance shutdowns
- Increased turbine availability
- Less fuel consumption
- Higher power output
- Extended turbine life
- Reduced life cycle costs (LCC)

APPLICATION AREAS

- Air inlets for gas turbine equipment
- Axial/reciprocating compressors
- Offshore and coastal installations
- Installations with recurrent high humidity
- Industrial and rural environment
- Dry, arid and arctic



CUTTING-EDGE INNOVATION FOR OPTIMAL FILTRATION

CamGT's supreme performance is based on Camfil's own construction featuring vertical pleats, hot melt separators and double-sealing design. The filter media packs are bonded to the inner surface of a robust plastic frame that features double sealing to eliminate bypass and withstand the often severe pressure fluctuations encountered in turbo machinery applications. For additional integrity, an aerodynamic grid is added to air exit sides. With the

uninterrupted molded polyurethane gasket permanently fixed to the filter frame, the filter installation is simplified and the risk for filter leakage is limited.

The vertical pleats and open separators allow trapped pleats water to drain freely from the filter during operation, thus avoiding re-entrainment of dissolved impurities and maintaining low pressure drop under high humidity conditions.



Solid and super-strong frame

Made from ABS plastic, the new CamGT filter withstands >6250 PA continuous in wet conditions. In combination with the double sealing and the new grid system, this solid frame also eliminates bypass air.



Optimized filter grades

Each filter grade is individually optimized for lowest pressure drop and maximum life.



EPA/HEPA tight construction

Improved and reinforced EPA/HEPA frame for a 100 percent leak-free product. Solid header. Patent pending double-sealing design.

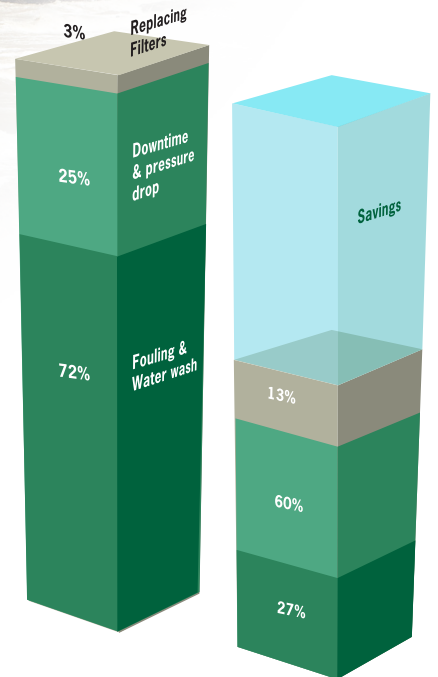

WHY HIGH-QUALITY FILTERS ACTUALLY COST LESS

By choosing a high quality filter and the right filter combination for your engine you can reduce the effects of fouling and degradation, thus lower the life cycle cost.

High-quality filters cost a little more initially. But in the long run, filters such as CamGT, which use the latest technology and the best filter media, actually lower your energy bill and your costs by maintaining their efficiency longer with the lowest pressure drop. Benefits such as higher power output, lower fuel consumption, reduced downtime and extended turbine life all combine to decrease your total cost of ownership.

What products meet your needs?

The air filtration marketplace includes products that present various advantages and disadvantages when compared to other air filter offerings. There are also different types of media incorporating varying principles of particle capture, each with its own advantage when applied in an inlet filter system. How can you and other filter users

differentiate manufacturers' claims and make sound decisions as to what products are applicable to meet your needs?

Make sure your turbine filters live up to the existing standards and to the desired performance in operation on site. Most importantly, choose quality.

The cost of clean air is not the cost of replacement filters

Turbine operators are requesting more and more that filter systems be optimized, not only in terms of price but also with regard to the total cost for the intake system, including filter usage, compressor cleaning, CO₂-emission costs, energy costs and other factors. We run calculations to determine the optimum combination of filters needed for the lowest total cost over

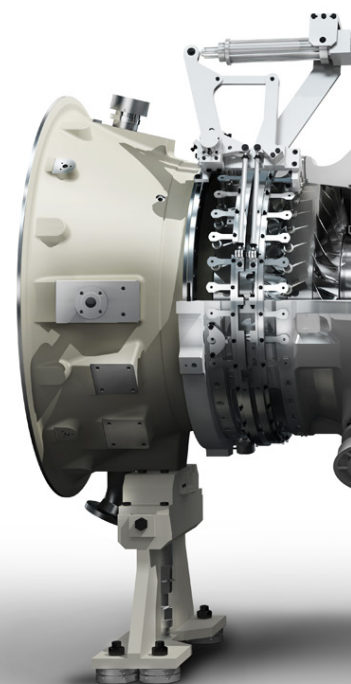

a given time period. Camfil's LCC program takes into account such factors as engine sensitivity, energy cost, running time, filter price, cleaning cost, different environments and filter characteristics. Our calculations are based on real-life testing data from a large number of sites.

**Not all filters are alike
– not even those who are in the same class**

One of the major problems of measuring and comparing filter performance is associated with electrostatic-charged synthetic filters. To pass a lab test these filters usually demonstrate good initial filtration efficiency while they keep their charge, but tend to discharge extremely rapidly, often after just a few weeks of operation. F9 performance in the lab for an electrostatic-charged

filter can therefore decrease to M6 in real operating conditions, and sometimes even more. Their filtration ability deteriorates considerably as a result. All Camfil filter products are tested according to the European standard for air filters (EN779:2012), which classifies air filters based on their minimum filtration efficiency (ME) eliminating the effect of charging.

A higher grade translates to lower life cycle costs

Gas turbine inlet filter systems have typically been designed with G4 pre-filtration and F7-9 (EN 779) final stage efficiency in static systems. This has provided an acceptable engine protection for many installations, but with an increasing use of gas turbines in urban environments engine degradation is sometimes rapid and water wash cycles

are often down to a few hundred hours.

Consequently, what is needed is better efficiency in removing small sub-micron particles, which mean minimum F9 efficiency or preferably stepping up to the EPA class range from E10 to E12 (EN 1822), which has a dramatic effect on engine fouling. For example, by going from the typical F8 grade to E12, penetration of 0.4 micron particles is reduced from typically 45 percent for an F8 filter to less than 0.5 percent in an E12 filter. This is a huge improvement that cuts fouling dramatically.

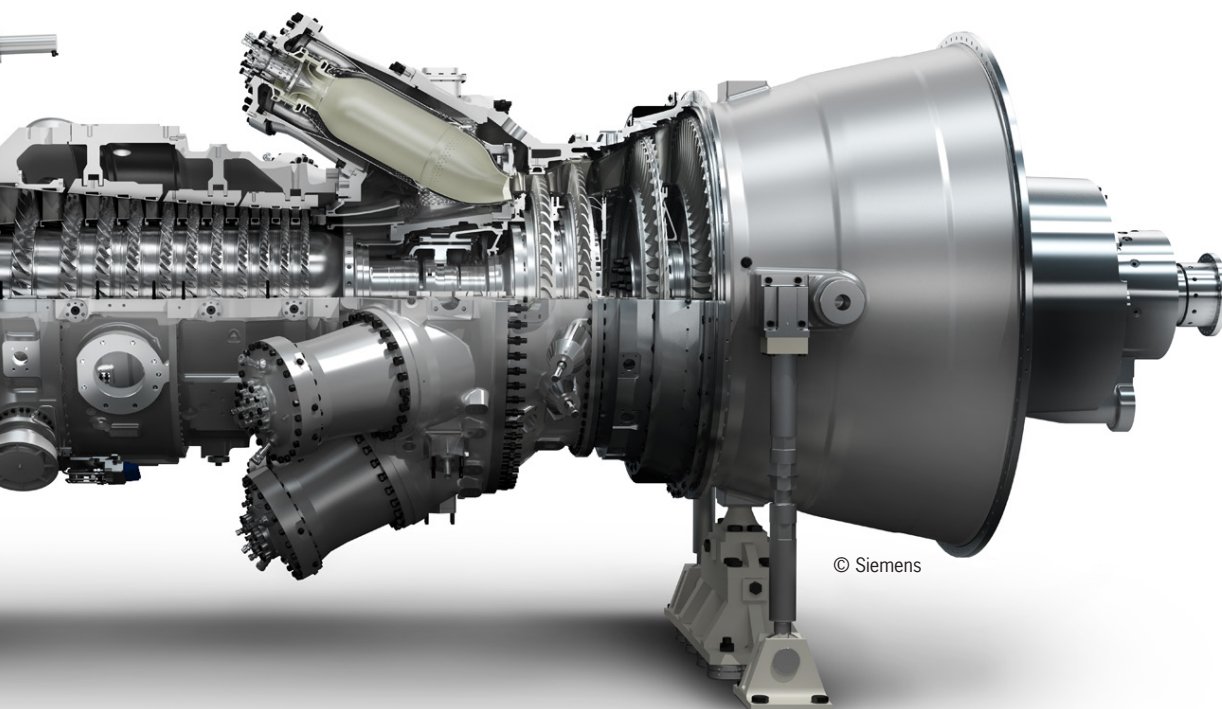
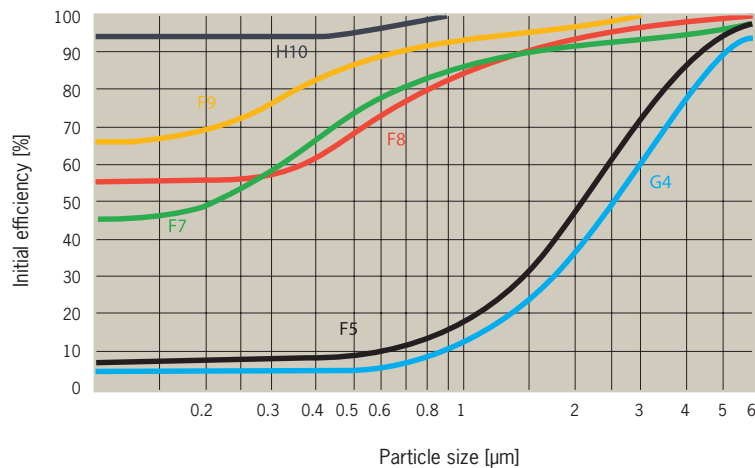

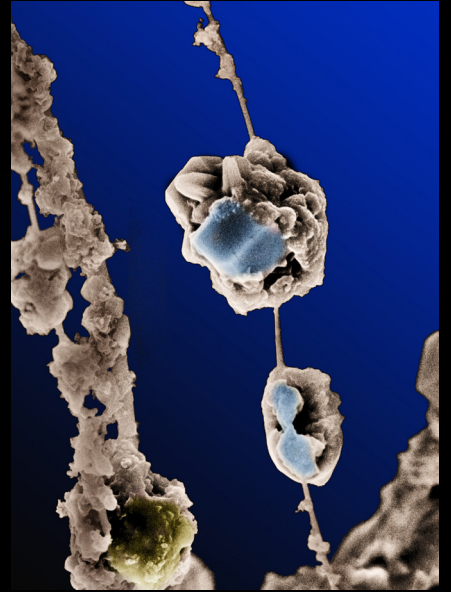

Using gas chromatography systems and scanning electron microscopes, we can perform advanced research into air quality.

In our various labs we continuously develop and test new products in order to make sure that we offer the best possible clean air solutions.



R&D IS IN OUR DNA

Camfil has an unusually high interest in technology. Since the company's inception, we have invested heavily in research and development, which we believe is one of our key success factors. At our highly modern tech center in Trosa, Sweden, we now have four brand new laboratories – a particle lab, a molecular lab, an IAQ lab and a gas turbine lab – complete with the latest technical equipment. The state of the art technology center is 2,500 m² and serves as an innovation hub for product and process solutions.

Dedicated GT filter test facilities

It is important to understand the complexity of differentiating air filters. Most air filters remain in a system for months or even years. However, testing of these filters

often occurs in a few minutes or hours. During its life, an air filter will see dozens or hundreds of environmental changes such as temperature, humidity, airflow velocity and particle load.

Camfil has invested in a full-scale climate chamber used to evaluate filtration needs under difficult circumstances. In our air filter testing laboratories we can modify all the important parameters such as airflow, relative humidity and salt content

CamLab

Camfill uses several mobile laboratories for evaluation of filters under real operating conditions. Air filters are monitored and analyzed for contaminant removal performance, mechanical structure integrity

and other important functions in various environmental conditions.

This laboratory carries sophisticated analysis equipment in order to evaluate existing products as well as develop new innovative air filter solutions. By remote access the system can be controlled and data can be retrieved from the test site in real time.

Camfil R&D is every day working closely together with end customers, research facilities and Camfil laboratories to expand the knowledge of air filtration by conducting long-term, real-life testing at numerous sites around the world.

COMPLETE SYSTEMS SUPPLIER FROM AIR INLET TO TOP OF STACK

Camfil Power Systems has been supplying cost-effective air intake systems and acoustic solutions to the industry for over 40 years. Our success is based on a development process in close collaboration with our customers and suppliers. Each solution is unique for you, as our customer.

Global presence

Thousands of our installations are used worldwide, around the clock, year after year. We operate globally but work locally. You always have a Camfil representative close at hand. We understand your needs – and speak your language.

Certification

We supply systems for gas turbines from 5 MW to over 300 MW. All our activities are controlled by our ISO-9001-certified quality control programme. We are also a certified SCC (Security Certificate Contractor), which is of crucial importance when performing installation and assembly operations.

Service and aftermarket

We have a carefully selected aftermarket service for spare parts and upgrade. Safe service guarantees reliable function and ensures you get the highest possible return on your investment.

Our automated production ensures high precision and quality.

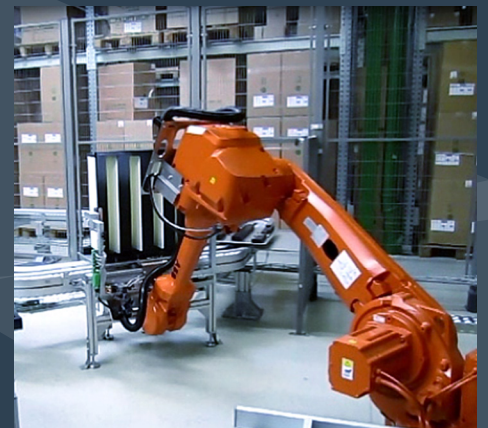

CamGT

4V-300 for turbomachinery

Pressure drop

CAM GT F-GRADE

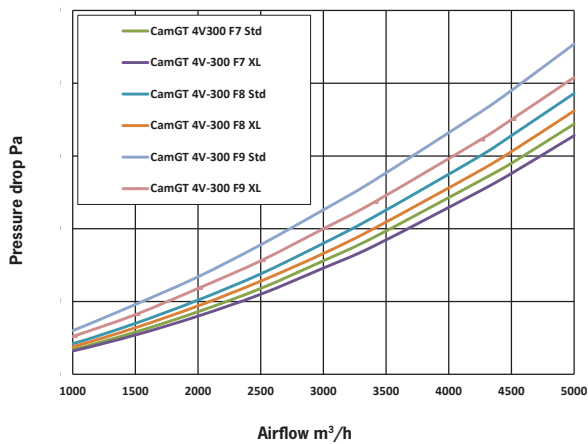

CAM GT E/H-GRADE

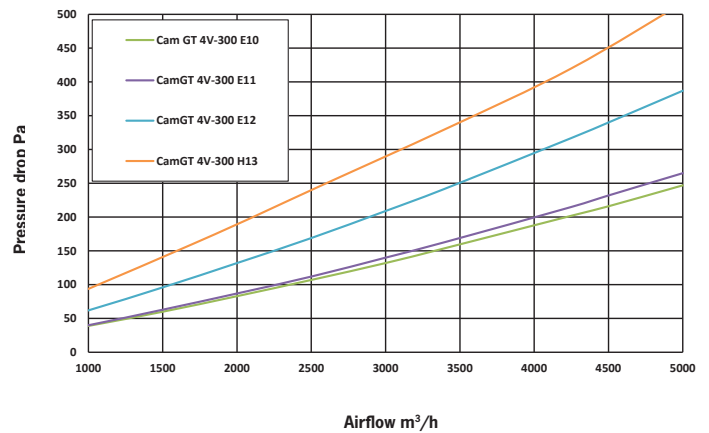

Technical data

Model	WxHxD		Frame		Media area m ² / ft ²	Air flow/Press. loss		Filter class EN779 / MERV
	mm	inch	m ³ /ft ³	kg/lb		m ³ /h/Pa	CFM/”wg	
Cam GT- F7	592×592×292	23.1/3×23.1/3×11.1/2	0.11/3.9	8.0/17.6	19.0/204	4250/135	2500/0.54	F7/MERV 13
Cam GT- F7 XL	592×592×292	23.1/3×23.1/3×11.1/2	0.11/3.9	8.5/18.7	26.0/280	4250/125	2500/0.51	F7/MERV 13
Cam GT- F8	592×592×292	23.1/3×23.1/3×11.1/2	0.11/3.9	8.0/17.6	19.0/204	4250/145	2500/0.58	F8/MERV 14
Cam GT- F8 XL	592×592×292	23.1/3×23.1/3×11.1/2	0.11/3.9	8.5/18.7	26.0/280	4250/135	2500/0.54	F8/MERV 14
Cam GT- F9	592×592×292	23.1/3×23.1/3×11.1/2	0.11/3.9	8.0/17.6	19.0/204	4250/170	2500/0.68	F9/MERV 15
Cam GT-F9 XL	592×592×292	23.1/3×23.1/3×11.1/2	0.11/3.9	8.5/18.7	26.0/280	4250/160	2500/0.64	F9/MERV 15
Cam GT- E10	592×592×292	23.1/3×23.1/3×11.1/2	0.11/3.9	8.5/18.7	29.0/312	4250/210	2500/0.84	E10/MERV 16
Cam GT- E11	592×592×292	23.1/3×23.1/3×11.1/2	0.11/3.9	8.5/18.7	29.0/312	4250/230	2500/0.86	E11
Cam GT- E12	592×592×292	23.1/3×23.1/3×11.1/2	0.11/3.9	9.0/19.8	30.0/323	4250/310	2500/1.24	E12
Cam GT- H13	592×592×292	23.1/3×23.1/3×11.1/2	0.11/3.9	9.0/19.8	30.0/323	3400/330	2000/1.32	H13

Type	Compact pleated filter	Rec. temperature	70°C/158°F max. operating temp.
Frame	Injection molded plastic parts	Rec. final pressure drop	600 Pa / 2.4” wg
Media	Pleated water resistant glass fiber	Burst strength	>6 250 Pa continuous wet/soaked
Separators	Hot melt	Efficiency class	EN1822:2009
Gasket	Continuous PU foam		EN779:2012
Seal	Polyurethane double sealing system		ASHRAE 52.2:2017

Application	All installations where safety/reliability is important
Additional information	Available in versions with Fire rating DIN4102 class b2, Reverse flow (also with support grid), 1/2 and 3/4 size on request.

Camfil Power Systems

Camfil – a global leader in air filters and clean air solutions

For more than half a century, Camfil has been helping people breathe cleaner air. As a leading manufacturer of premium clean air solutions, we provide commercial and industrial systems for air filtration and air pollution control that improve worker and equipment productivity, minimize energy use, and benefit human health and the environment. We firmly believe that the best solutions for our customers are the best solutions for our planet, too. That's why every step of the way – from design to delivery and across the product life cycle – we consider the impact of what we do on people and on the world around us. Through a fresh approach to problem-solving, innovative design, precise process control and a strong customer focus we aim to conserve more, use less and find better ways – so we can all breathe easier.

The Camfil Group is headquartered in Stockholm, Sweden, and has 28 manufacturing sites, six R&D centres, local sales offices in 26 countries, and 4,180 employees and growing. We proudly serve and support customers in a wide variety of industries and in communities across the world. To discover how Camfil can help you to protect people, processes and the environment, visit us at www.camfil.com.

www.camfil.com

For further information please contact your nearest Camfil office.